



ATLANTIC
Fluid Tech

**SECTION
5**

Pilot
Operated
Check Valves

PILOT OPERATED CHECK VALVES

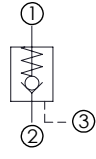
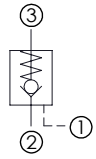
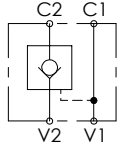
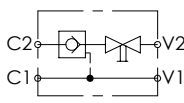
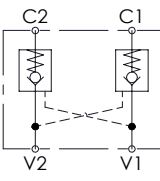
Hydraulic scheme	Valve description	Valve type	Rated flow l/min (gpm)	Max. pressure bar (psi)	Installation	Main port size or cavity type	Page
	CDPN-030-PSGR	Poppet type	30 (8)	350 (5000)	Cartridge	SAE-08-3C	5.01.010
	CDPN-060-PSGR	Poppet type	60 (16)	350 (5000)	Cartridge	SAE-10-3C	5.01.020
	CDPN-060-PSGR	Poppet type	60 (16)	350 (5000)	Cartridge	VP000161 (F-11A)	5.01.030
	CDPN-120-PSGR	Poppet type	120 (32)	350 (5000)	Cartridge	VP000165 (F-2A)	5.01.040
	CDPN-030-PANR	Integral pilot piston	30 (8)	350 (5000)	Cartridge	SAE-10-3N	5.02.045
	CDPN-030-PANR	Poppet type	30 (8)	350 (5000)	Cartridge	VP000314	5.02.050
	CDPN-030-PSNE	Poppet type, separate pilot piston	30 (8)	350 (5000)	Cartridge	VP000028	5.02.060
	MCSN-020-SLAC	Single acting, poppet type	20 (5)	350 (5000)	In line	G 1/4"	5.03.070
	MCSN-030-TLNS	Single acting, poppet type	30 (8)	350 (5000)	In line	G 3/8"	5.03.080
	MCSN-030-TANS	Single acting, poppet type	30 (8)	350 (5000)	Flanged	G 3/8"	5.03.090
	MCSN-060-TLNS	Single acting, poppet type	60 (16)	350 (5000)	In line	G 1/2"	5.03.100
	MCSN-060-TANS	Single acting, poppet type	60 (16)	350 (5000)	Flanged	G 1/2"	5.03.110
	MCSN-100-TLNS	Single acting, poppet type	100 (26)	350 (5000)	In line	G 3/4"	5.03.120
	MCSN-020-TLLC	Single acting, manual shut off, left version	20 (5)	210 (3000)	In line	G 3/8"	5.04.130
	MCSN-020-TLRC	Single acting, manual shut off, right version	20 (5)	210 (3000)	In line	G 3/8"	5.04.140
	MCDN-020-SLAS	Double acting, poppet type	20 (5)	350 (5000)	In line	G 1/4"	5.05.150
	MCDN-020-SLAS	Double acting, poppet type, steel body	20 (5)	350 (5000)	In line	G 3/8"	5.05.160
	MCDN-020-SPAS	Double acting, poppet type, with banjo	20 (5)	350 (5000)	In line	G 3/8"	5.05.170
	MCDN-030-TLNS	Double acting, poppet type	30 (8)	350 (5000)	In line	G 3/8"	5.05.180
	MCDN-030-ZBNS	Double acting, poppet type	30 (8)	350 (5000)	Flanged	G 3/8"	5.05.190
	MCDN-030-TBNS	Double acting, poppet type	30 (8)	350 (5000)	Flanged	G 1/4"	5.05.200
	MCDN-030-SBNS	Double acting, poppet type, steel body	30 (8)	350 (5000)	Flanged	G 3/8"	5.05.210
	MCDN-060-TLNS	Double acting, poppet type	60 (16)	350 (5000)	In line	G 1/2"	5.05.220
	MCDN-060-TBNS	Double acting, poppet type	60 (16)	350 (5000)	Flanged	G 1/2"	5.05.230
	MCDN-100-LLNR	Double acting, poppet type	100 (26)	350 (5000)	In line	G 3/4"	5.05.240

PILOT OPERATED CHECK VALVE

CDPN-030-PSGR

INTEGRAL PILOT
PISTON

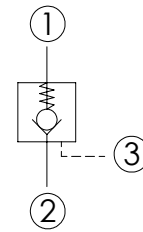
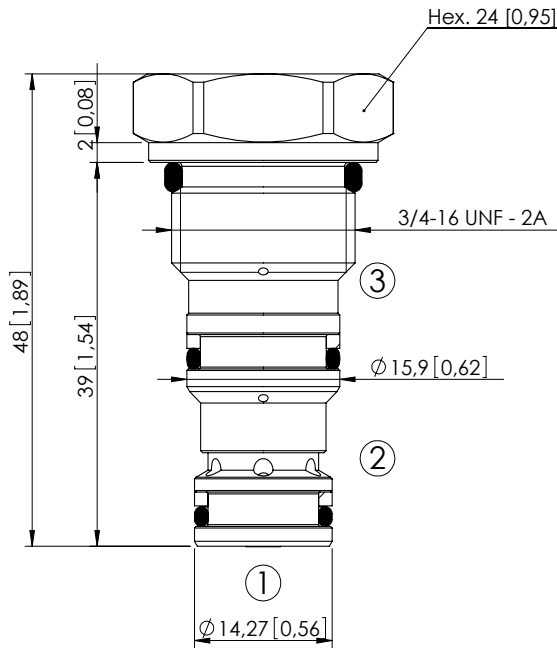

SPECIFICATIONS

Max. operating pressure:	350 bar (5000 psi)
Rated flow:	30 l/min (8 gpm)
Cavity:	SAE-08-3C
Weight:	0,09 kg (0,2 lbs)
Pilot ratio:	3:1
Contamination class to ISO 4406:	See technical spec.
Seal kit:	RA700086
Installation torque:	40 - 45 Nm (30 - 33 ft-lb)
MTF _d :	150 - 1200 years: See technical spec.

Dimensions: mm [inches]

NOTES

For other configurations/quick codes not available in this catalogue page please consult factory

CURVES

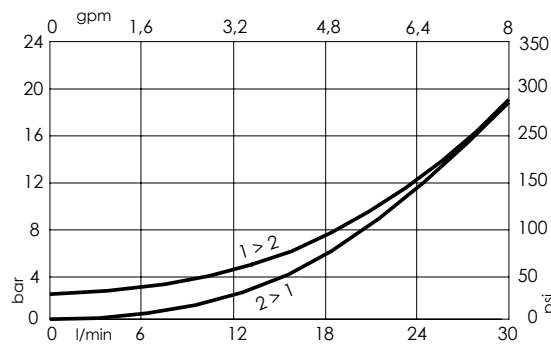

ORDERING CODES

Quick code	Description	Cracking pressure	O-ring on pilot piston
CD000027	CDPN-030-PSGR-03-S08-N002	2 bar (25 psi)	YES
CD000061	CDPN-030-PSGM-03-S08-N002	2 bar (25 psi)	NO

PILOT OPERATED CHECK VALVE

CDPN-060-PSGR

INTEGRAL PILOT
PISTON

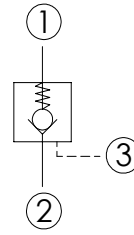
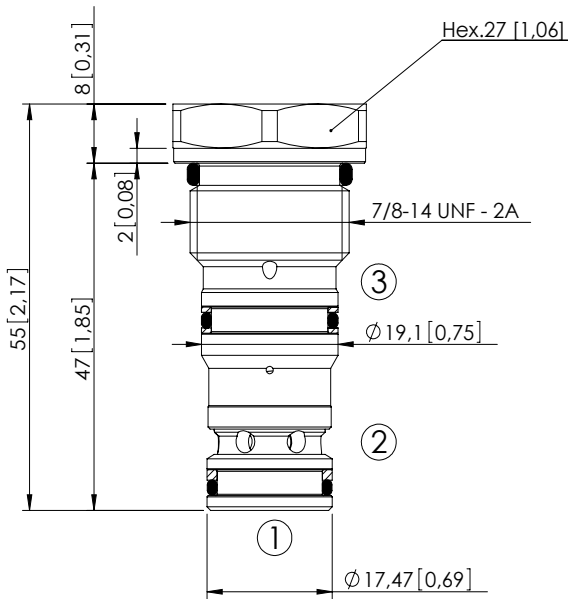

SPECIFICATIONS

Max. operating pressure:	350 bar (5000 psi)
Rated flow:	60 l/min (16 gpm)
Cavity:	SAE-10-3C
Weight:	0,12 kg (0,27 lbs)
Pilot ratio:	3,2 : 1
Contamination class to ISO 4406:	See technical spec.
Seal kit:	RB700087
Installation torque:	55 - 62 Nm (41 - 46 ft-lb)
MTTF _a :	150 - 1200 years: See technical spec.

Dimensions: mm [inches]

NOTES

For other configurations/quick codes not available in this catalogue page please consult factory

CURVES

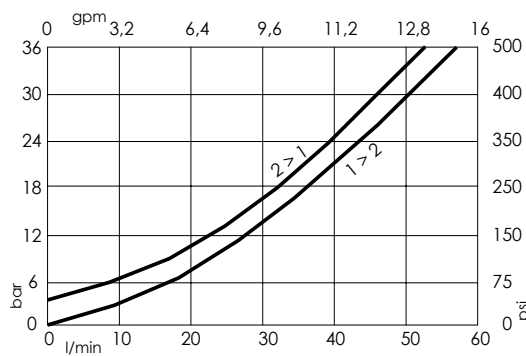

ORDERING CODES

Quick code	Description	Cracking pressure	O-ring on pilot piston
CD000109	CDPN-060-PSGR-03-S10-N002	2 bar (25 psi)	YES
CD000113	CDPN-060-PSGM-03-S10-N002	2 bar (25 psi)	NO
CD000170	CDPN-060-PSGR-03-S10-N005	5 bar (75 psi)	YES
CD000171	CDPN-060-PSGM-03-S10-N005	5 bar (75 psi)	NO

PILOT OPERATED CHECK VALVE

CDPN-060-PSGR

INTEGRAL PILOT PISTON

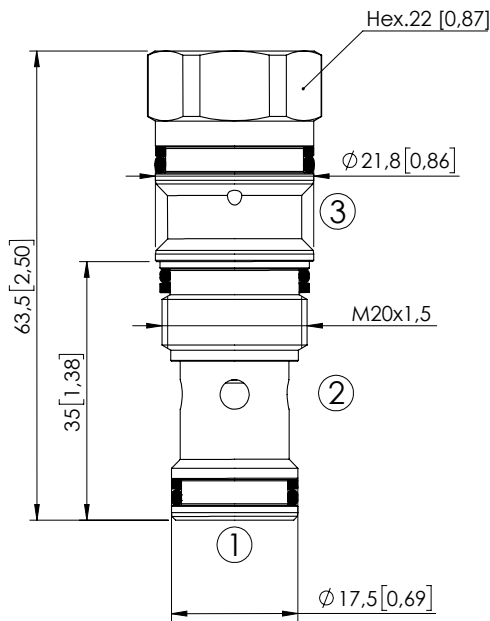

Dimensions: mm [inches]

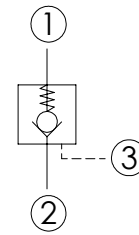

SPECIFICATIONS

Max. operating pressure:	350 bar (5000 psi)
Rated flow:	60 l/min (16 gpm)
Cavity:	VP000161 (SUN T-11A)
Weight:	0,12 kg (0,27 lbs)
Pilot ratio:	3,2:1
Contamination class to ISO 4406:	See technical spec.
Seal kit:	RC700161
Installation torque:	40 - 50 Nm (30 - 37 ft-lb)
MTF _a :	150 - 1200 years: See technical spec.

NOTES

For other configurations/quick codes not available in this catalogue page please consult factory

CURVES

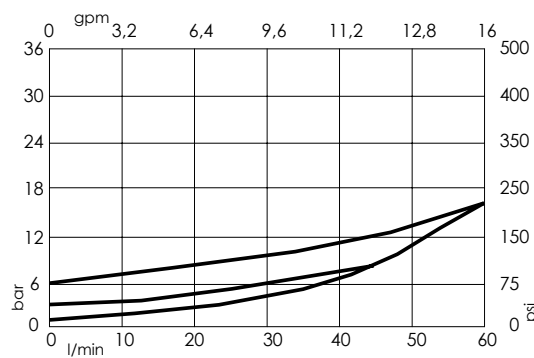

ORDERING CODES

Quick code	Description	Cracking pressure	O-ring on pilot piston
CD000555	CDPN-060-PSGR-03-161-N000	0,3 bar (5 psi)	YES
CD000226	CDPN-060-PSGR-03-161-N002	2 bar (25 psi)	YES
CD000227	CDPN-060-PSGM-03-161-N002	2 bar (25 psi)	NO
CD000224	CDPN-060-PSGR-03-161-N005	5 bar (75 psi)	YES
CD000225	CDPN-060-PSGM-03-161-N005	5 bar (75 psi)	NO

PILOT OPERATED CHECK VALVE

CDPN-120-PSGR

INTEGRAL PILOT PISTON

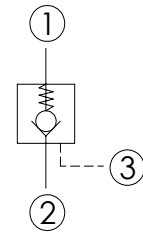
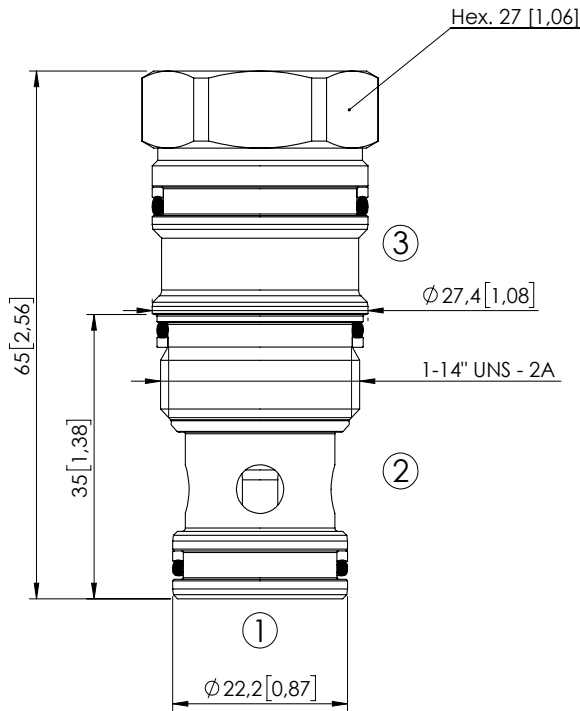

SPECIFICATIONS

Max. operating pressure:	350 bar (5000 psi)
Rated flow:	120 l/min (32 gpm)
Cavity:	VP000165 (SUN T-2A)
Weight:	0,2 kg (0,44 lbs)
Pilot ratio:	3,5 : 1
Contamination class to ISO 4406:	See technical spec.
Seal kit:	RC700165
Installation torque:	60 - 65 Nm (44 - 48 ft-lb)
MTF _d :	150 - 1200 years: See technical spec.

Dimensions: mm [inches]

NOTES

For other configurations/quick codes not available in this catalogue page please consult factory

CURVES

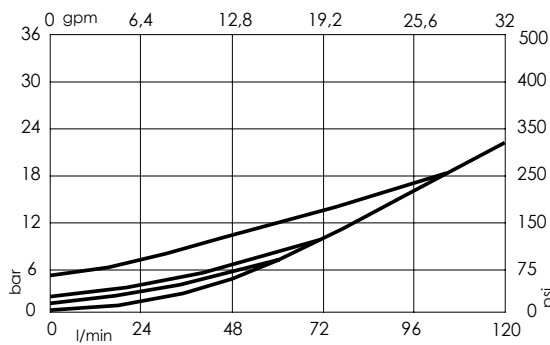

ORDERING CODES

Quick code	Description	Cracking pressure	O-ring on pilot piston
CD000546	CDPN-120-PSGR-03-165-N000	0,3 bar (5 psi)	NO
CD000504	CDPN-120-PSGR-03-165-N002	2 bar (25 psi)	YES
CD000549	CDPN-120-PSGM-03-165-N002	2 bar (25 psi)	NO
CD000536	CDPN-120-PSGM-03-165-N003	3 bar (50 psi)	NO
CD000547	CDPN-120-PSGR-03-165-N005	5 bar (75 psi)	YES

PILOT OPERATED CHECK VALVE

CDPN-030-PANR

INTEGRAL PILOT PISTON

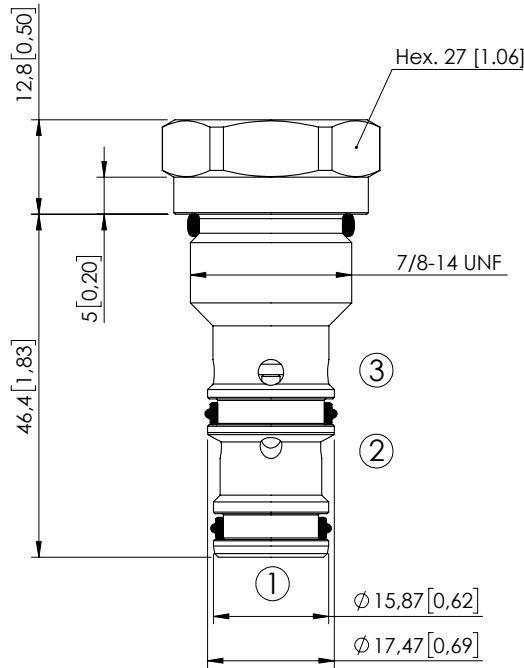

Dimensions: mm [inches]

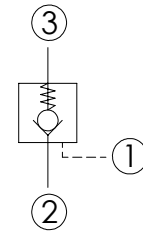

SPECIFICATIONS

Max. operating pressure:	350 bar (5000 psi)
Rated flow:	30 l/min (8 gpm)
Cavity:	SAE-10-3N
Weight:	0,13 kg (0,28 lbs)
Pilot ratio:	4:1
Contamination class to ISO 4406:	See technical spec.
Seal kit:	RB600092
Installation torque:	55 - 62 Nm (41 - 46 ft-lb)
MTTFa:	150 years

NOTES

For other configurations/quick codes not available in this catalogue page please consult factory

CURVES

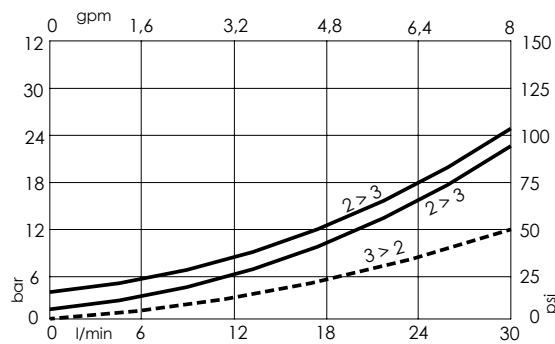

ORDERING CODES

Quick code	Description	Cracking pressure	O-ring on pilot piston
CD000631	CDPN-030-PANR-04-S10-N002	2 bar (30 psi)	YES
CD000632	CDPN-030-PANR-04-S10-N004	4 bar (60 psi)	YES

PILOT OPERATED CHECK VALVE

CDPN-030-PANR

INTEGRAL PILOT
PISTON

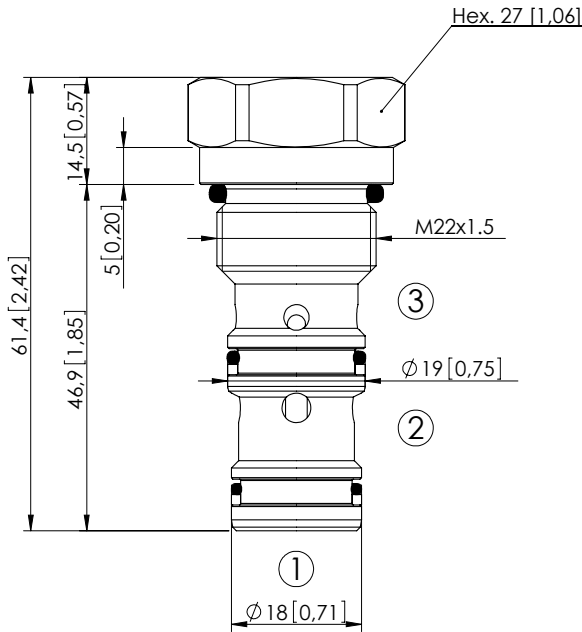

Dimensions: mm [inches]

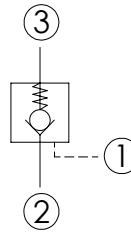

SPECIFICATIONS

Max. operating pressure:	350 bar (5000 psi)
Rated flow:	30 l/min (8 gpm)
Cavity:	VP000314
Weight:	0,1 kg (0,22 lbs)
Pilot ratio:	4 : 1
Contamination class to ISO 4406:	See technical spec.
Seal kit:	RC700314
Installation torque:	55 - 62 Nm (41 - 46 ft-lb)
MTF ^a :	150 - 1200 years: See technical spec.

NOTES

For other configurations/quick codes not available in this catalogue page please consult factory

CURVES

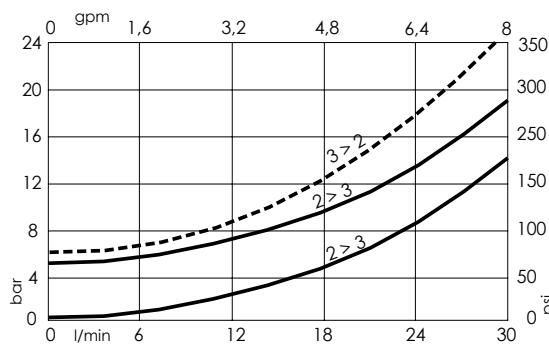

ORDERING CODES

Quick code	Description	Cracking pressure	O-ring on pilot piston
CD000186	CDPN-030-PANR-04-314-N005	5 bar (75 psi)	YES
CD000235	CDPN-030-PANM-04-314-N001	1 bar (15 psi)	NO

PILOT OPERATED CHECK VALVE

CDPN-030-PSNE

SEPARATE PILOT PISTON

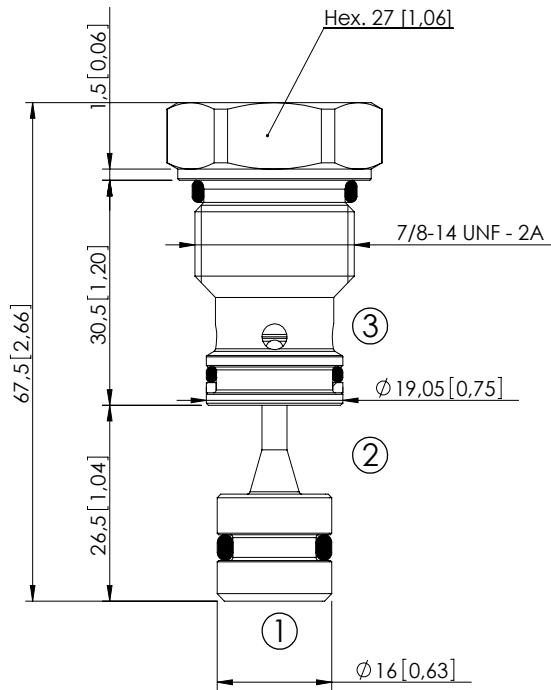

Dimensions: mm [inches]

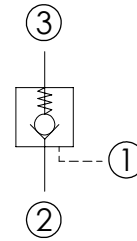

SPECIFICATIONS

Max. operating pressure:	350 bar (5000 psi)
Rated flow:	30 l/min (8 gpm)
Cavity:	VP000028
Weight:	0,13 kg (0,29 lbs)
Pilot ratio:	7:1
Contamination class to ISO 4406:	See technical spec.
Installation torque:	80 - 90 Nm (59 - 66 ft-lb)
MTTF _a :	150 - 1200 years: See technical spec.

NOTES

For other configurations/quick codes not available in this catalogue page please consult factory

CURVES

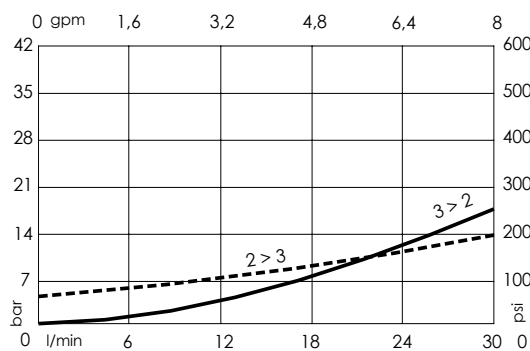

ORDERING CODES

Quick code	Description	Cracking pressure	O-ring on pilot piston
SC000002	CDPN-030-PSNE-07-028-N005	4,5 bar (75 psi)	YES
SC000044	CDPN-030-PSNN-07-028-N005	4,5 bar (75 psi)	NO

PILOT OPERATED CHECK VALVE

MCSN-020-SLAC

SINGLE ACTING

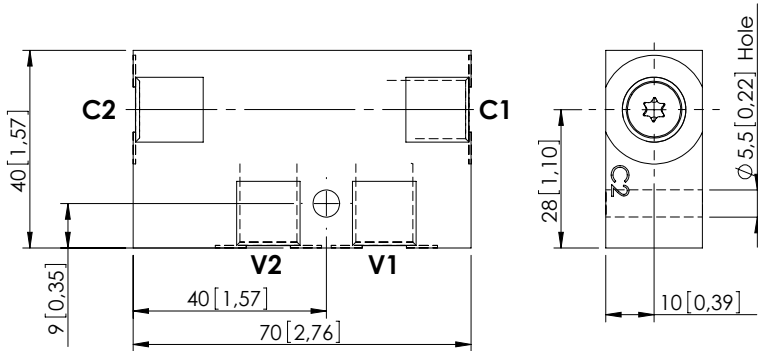
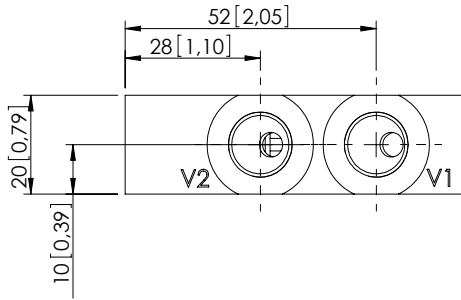

Dimensions: mm [inches]

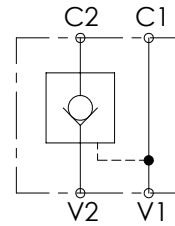

SPECIFICATIONS

Max. operating pressure:	350 bar (5000 psi)
Rated flow:	20 l/min (6 gpm)
Manifold:	Steel
Weight:	0,36 kg (0,79 lbs)
Contamination class to ISO 4406:	See technical spec.
MTTF _a :	150 - 1200 years: See technical spec.

NOTES

For other configurations/quick codes not available in this catalogue page please consult factory

CURVES

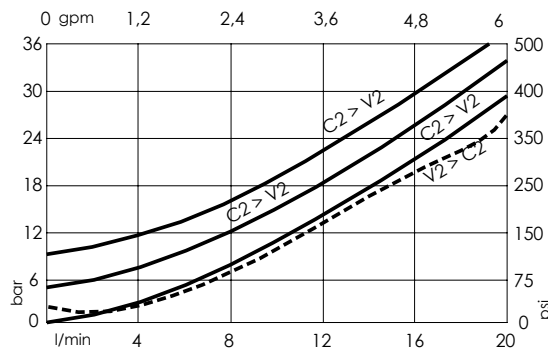

ORDERING CODES

Quick code	Description	Main ports size	Pilot ratio	Cracking pressure	O-ring on pilot piston
MC000059	MCSN-020-SLAC-04-G14-N003	V1,V2,C1,C2 : G 1/4"	4:1	3 bar (50 psi)	YES
MC000094	MCSN-020-SLAC-04-G14-N008	V1,V2,C1,C2 : G 1/4"	4:1	8 bar (100 psi)	YES
MC000097	MCSN-020-SLAC-07-G14-N005	V1,V2,C1,C2 : G 1/4"	7:1	5 bar (75 psi)	YES

PILOT OPERATED CHECK VALVE

MCSN-030-TLNS

SINGLE ACTING

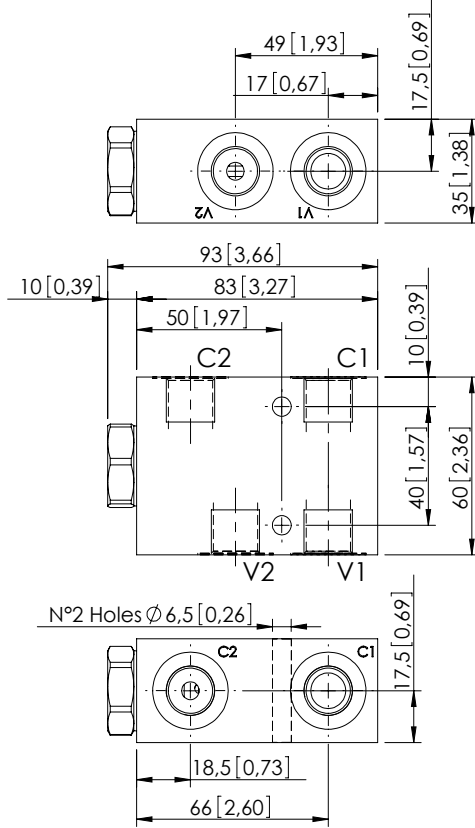

Dimensions: mm [inches]

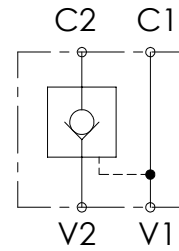

SPECIFICATIONS

Max. operating pressure:	350 bar (5000 psi)
Rated flow:	30 l/min (8 gpm)
Manifold:	Aluminium
Weight:	0,49 kg (1,08 lbs)
Contamination class to ISO 4406:	See technical spec.
MTTFa:	150 - 1200 years: See technical spec.

NOTES

For other configurations/quick codes not available in this catalogue page please consult factory

CURVES

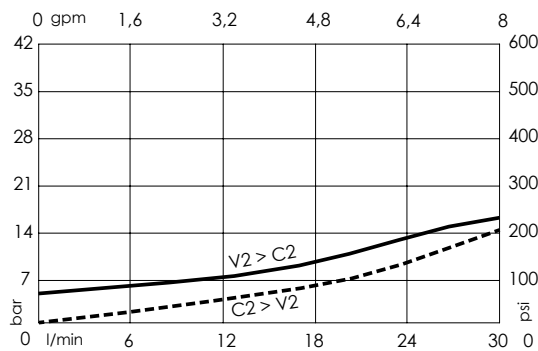

ORDERING CODES

Quick code	Description	Main ports size	Pilot ratio	Cracking pressure	O-ring on pilot piston
MC000078	MCSN-030-TLNS-07-G38-N005	V1,V2,C1,C2 : G 3/8"	7:1	5 bar (75 psi)	NO
MC000075	MCSN-030-TLNC-07-G38-N005	V1,V2,C1,C2 : G 3/8"	7:1	5 bar (75 psi)	YES

PILOT OPERATED CHECK VALVE

MCSN-030-TANS

SINGLE ACTING
ONE FLANGED PORT

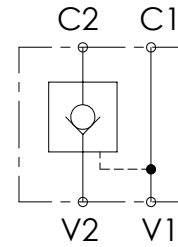
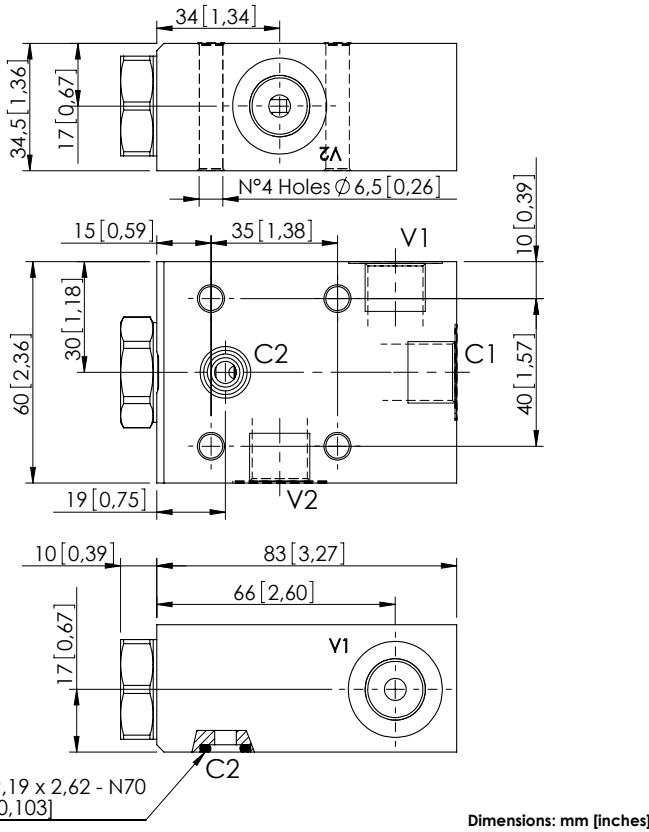

SPECIFICATIONS

Max. operating pressure:	350 bar (5000 psi)
Rated flow:	30 l/min (8 gpm)
Manifold:	Aluminium
Weight:	0,49 kg (1,08 lbs)
Contamination class to ISO 4406:	See technical spec.
MTTF _d :	150 - 1200 years: See technical spec.

NOTES

For other configurations/quick codes not available in this catalogue page please consult factory

CURVES

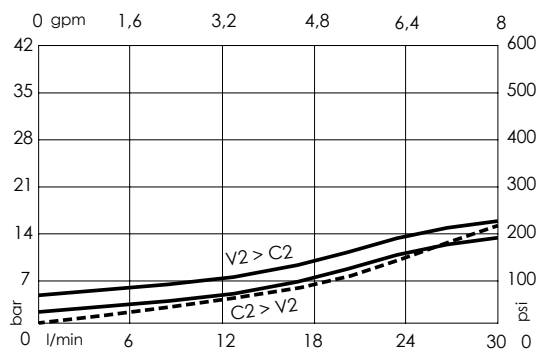

ORDERING CODES

Quick code	Description	Main ports size	Pilot ratio	Cracking pressure	O-ring on pilot piston
MC000064	MCSN-030-TANS-07-G38-N001	V1,V2,C1: G 3/8" C2: \varnothing 6	7:1	1 bar (15 psi)	NO
MC000066	MCSN-030-TANS-07-G38-N005	V1,V2,C1: G 3/8" C2: \varnothing 6	7:1	5 bar (75 psi)	NO
MC000068	MCSN-030-TANC-07-G38-N005	V1,V2,C1: G 3/8" C2: \varnothing 6	7:1	5 bar (75 psi)	YES

PILOT OPERATED CHECK VALVE

MCSN-060-TLNS

SINGLE ACTING

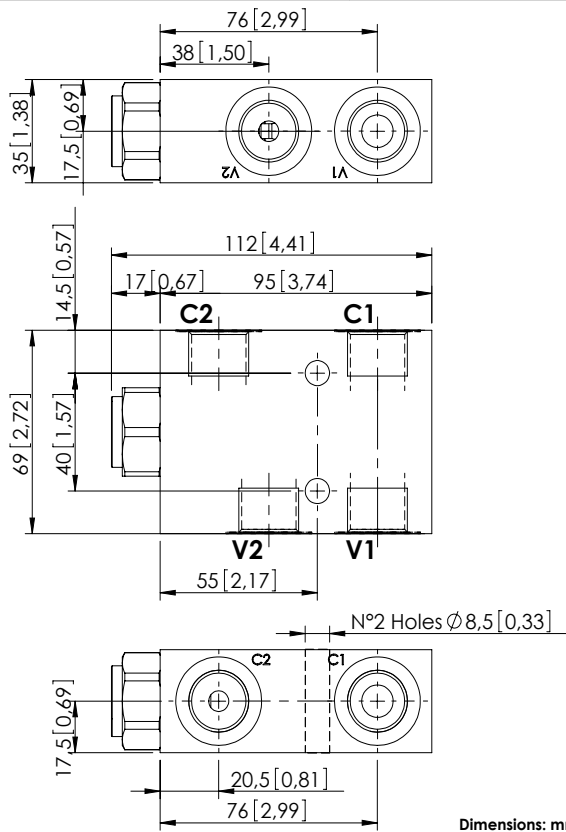

Dimensions: mm [inches]

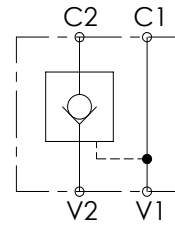

SPECIFICATIONS

Max. operating pressure:	350 bar (5000 psi)
Rated flow:	60 l/min (16 gpm)
Manifold:	Aluminium
Weight:	0,66 kg (1,46 lbs)
Contamination class to ISO 4406:	See technical spec.
MTF _d :	150 - 1200 years: See technical spec.

NOTES

For other configurations/quick codes not available in this catalogue page please consult factory

CURVES

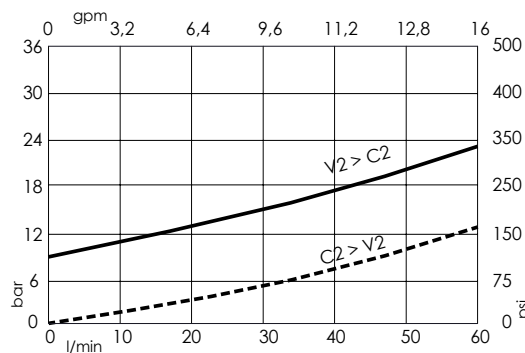

ORDERING CODES

Quick code	Description	Main ports size	Pilot ratio	Cracking pressure	O-ring on pilot piston
MC000079	MCSN-060-TLNS-03-G12-N009	V1,V2,C1,C2 : G 1/2"	3:1	9 bar (130 psi)	NO
MC000076	MCSN-060-TLNC-03-G12-N009	V1,V2,C1,C2 : G 1/2"	3:1	9 bar (130 psi)	YES

Revision A1

PILOT OPERATED CHECK VALVE

MCSN-060-TANS

SINGLE ACTING
ONE FLANGED PORT

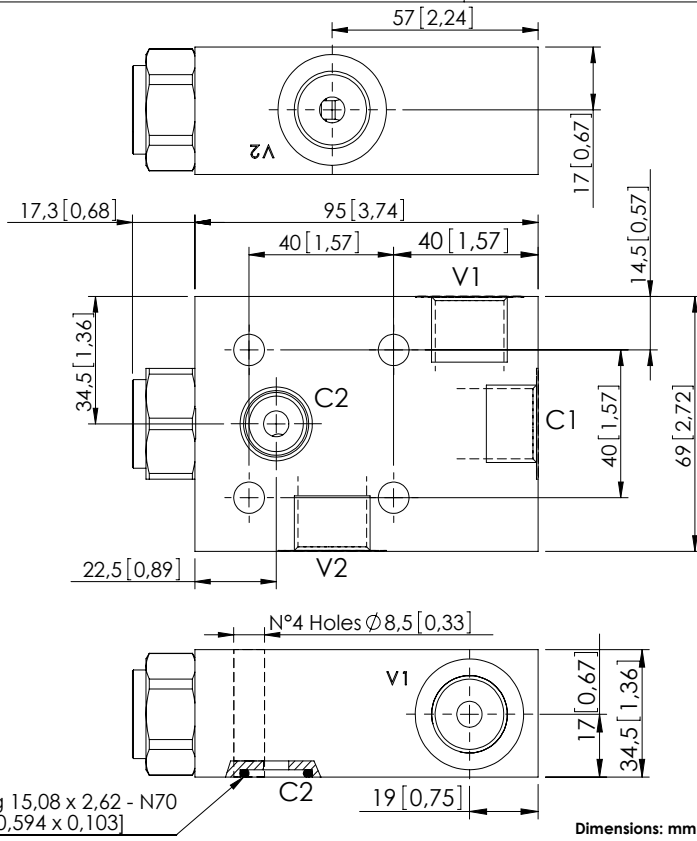

O-Ring 15,08 x 2,62 - N70
[0,594 x 0,103]

Dimensions: mm [inches]

NOTES

For other configurations/quick codes not available in this catalogue page please consult factory

CURVES

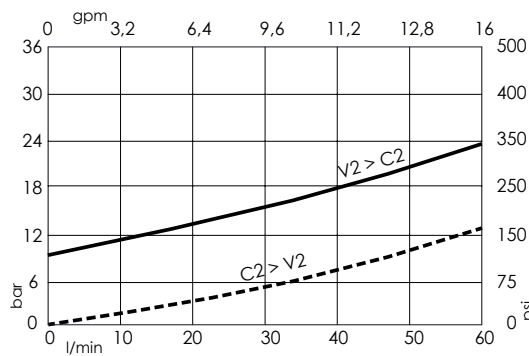

ORDERING CODES

Quick code	Description	Main ports size	Pilot ratio	Cracking pressure	O-ring on pilot piston
MC000080	MCSN-060-TANS-03-G12-N009	V1,V2,C1: G 1/2" C2: Ø 7	3:1	9 bar (130 psi)	NO
MC000077	MCSN-060-TANC-03-G12-N009	V1,V2,C1: G 1/2" C2: Ø 7	3:1	9 bar (130 psi)	YES

PILOT OPERATED CHECK VALVE

MCSN-100-TLNS

SINGLE ACTING

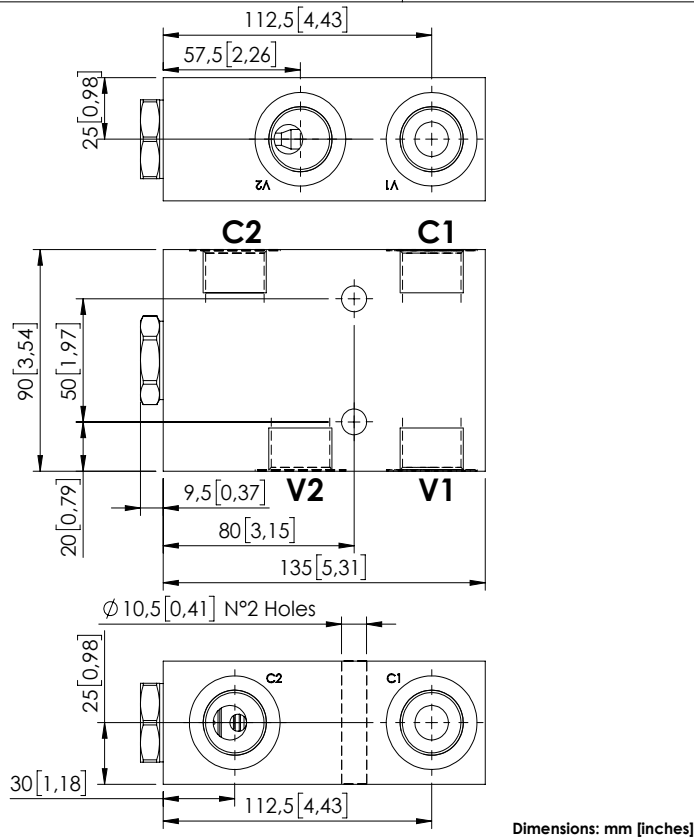

Dimensions: mm [inches]

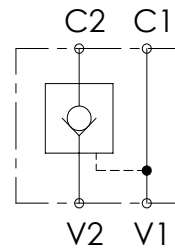

SPECIFICATIONS

Max. operating pressure:	350 bar (5000 psi)
Rated flow:	100 l/min (26 gpm)
Manifold:	Aluminium
Weight:	1,5 kg (3,31 lbs)
Contamination class to ISO 4406:	See technical spec.
MTF _a :	150 - 1200 years: See technical spec.

NOTES

For other configurations/quick codes not available in this catalogue page please consult factory

CURVES

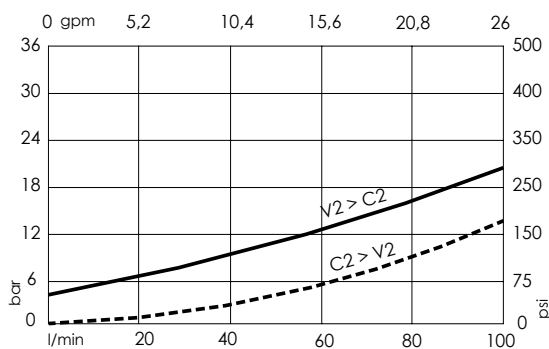

ORDERING CODES

Quick code	Description	Main ports size	Pilot ratio	Cracking pressure	O-ring on pilot piston
MC000148	MCSN-100-TLNS-04-G34-N004	V1,V2,C1,C2 : G 3/4"	4:1	4 bar (50 psi)	NO

PILOT OPERATED CHECK VALVE

MCSN-020-TLLC

SINGLE ACTING
MANUAL SHUT OFF
LEFT VERSION

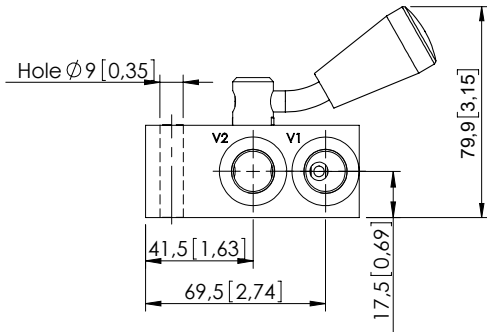

Open

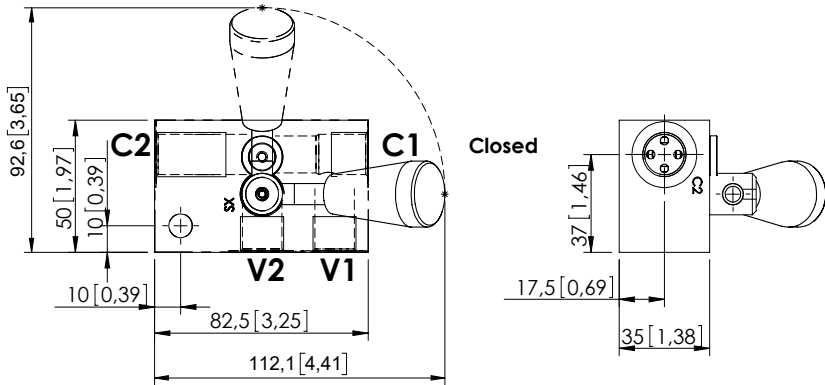

Dimensions: mm [inches]

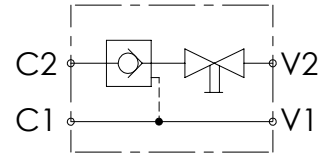

SPECIFICATIONS

Max. operating pressure:	350 bar (5000 psi)
Rated flow:	20 l/min (5 gpm)
Manifold:	Aluminium
Weight:	0.45 kg (0,99 lbs)
Contamination class to ISO 4406:	See technical spec.
MTTFa:	150 - 1200 years: See technical spec.

NOTES

For other configurations/quick codes not available in this catalogue page please consult factory

CURVES

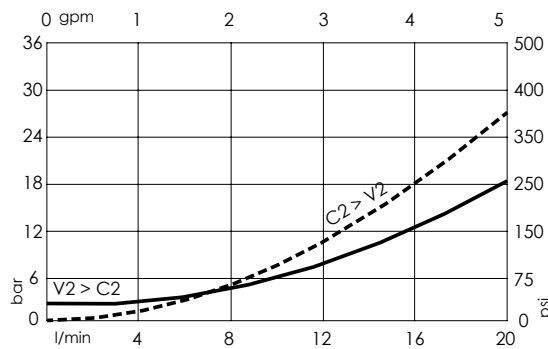

ORDERING CODES

Quick code	Description	Main ports size	Pilot ratio	Cracking pressure	O-ring on pilot piston
MC000062	MCSN-020-TLLC-05-G38-N002	V1,V2,C1,C2 : G 3/8"	5:1	2 bar (25 psi)	YES

PILOT OPERATED CHECK VALVE

MCSN-020-TLRC

SINGLE ACTING
MANUAL SHUT OFF
RIGHT VERSION

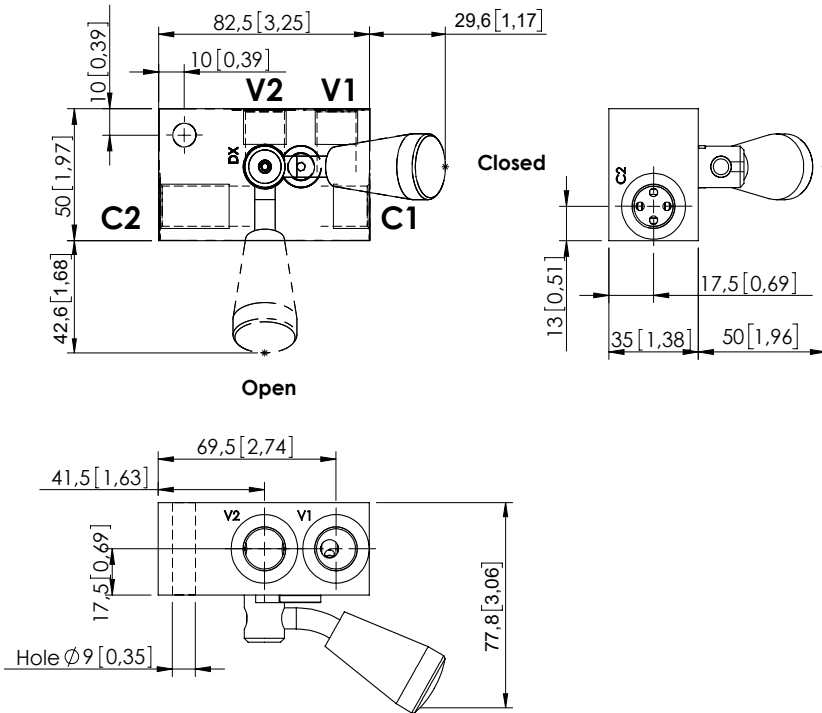

Dimensions: mm [inches]

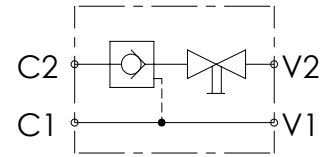

SPECIFICATIONS

Max. operating pressure:	350 bar (5000 psi)
Rated flow:	20 l/min (5 gpm)
Manifold:	Aluminium
Weight:	0.45 kg (0,99 lbs)
Contamination class to ISO 4406:	See technical spec.
MTF _a :	150 - 1200 years: See technical spec.

NOTES

For other configurations/quick codes not available in this catalogue page please consult factory

CURVES

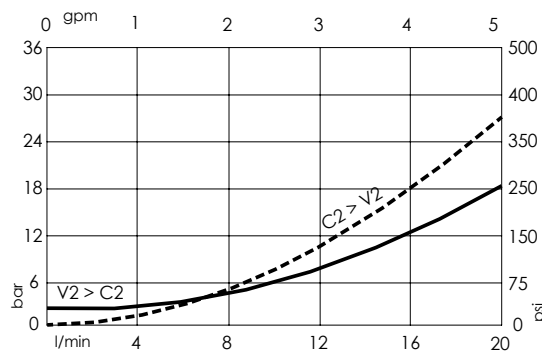

ORDERING CODES

Quick code	Description	Main ports size	Pilot ratio	Cracking pressure	O-ring on pilot piston
MC000061	MCSN-020-TLRC-05-G38-N002	V1,V2,C1,C2 : G 3/8"	5:1	2 bar (25 psi)	YES

PILOT OPERATED CHECK VALVE

MCDN-020-SLAS

DOUBLE ACTING

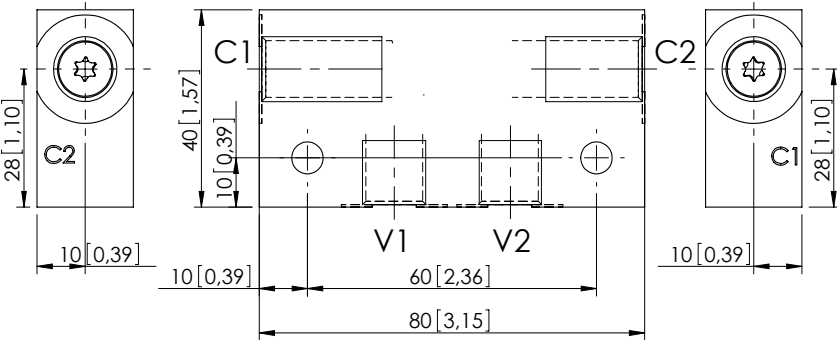
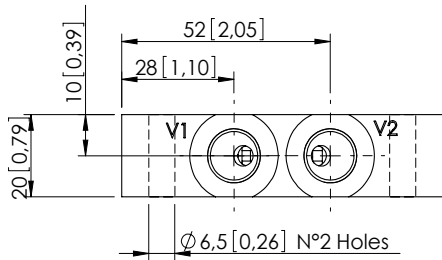

Dimensions: mm [inches]

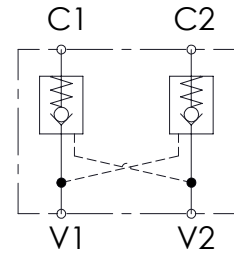

SPECIFICATIONS

Max. operating pressure:	350 bar (5000 psi)
Rated flow:	20 l/min (5 gpm)
Manifold:	Steel
Weight:	0,42 kg (0,93 lbs)
Contamination class to ISO 4406:	See technical spec.
MTF _d :	150 - 1200 years: See technical spec.

NOTES

For other configurations/quick codes not available in this catalogue page please consult factory

CURVES

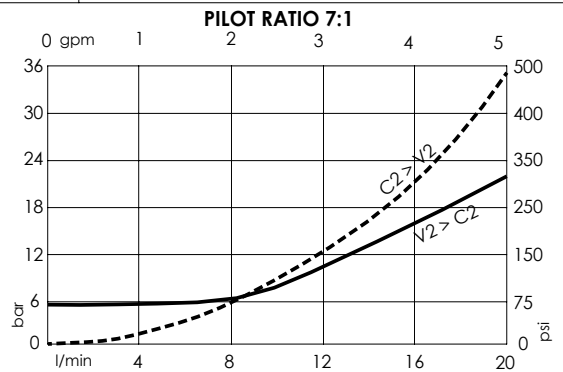
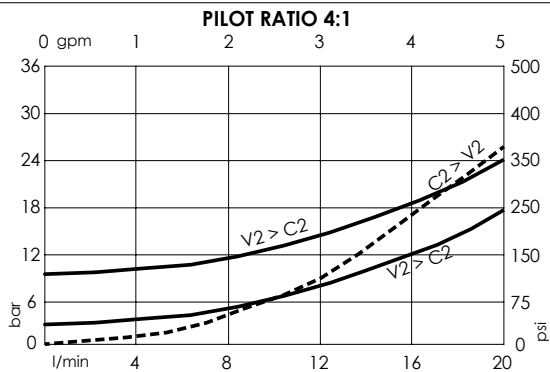

ORDERING CODES

Quick code	Description	Main ports size	Pilot ratio	Cracking pressure	O-ring on pilot piston
MC000113	MCDN-020-SLAS-04-G14-N003	V1,V2,C1,C2 : G 1/4"	4:1	3 bar (100 psi)	NO
MC000160	MCDN-020-SLAS-04-G14-N008	V1,V2,C1,C2 : G 1/4"	4:1	8 bar (100 psi)	NO
MC000227	MCDN-020-SLAS-07-G14-N005	V1,V2,C1,C2 : G 1/4"	7:1	5 bar (75 psi)	NO

Revision C1

PILOT OPERATED CHECK VALVE

MCDN-020-SLAS

DOUBLE ACTING

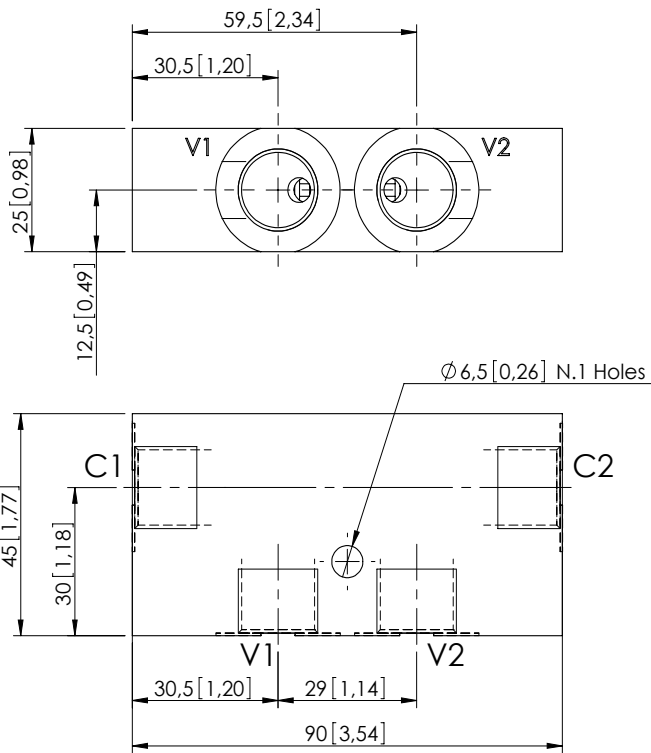

Dimensions: mm [inches]

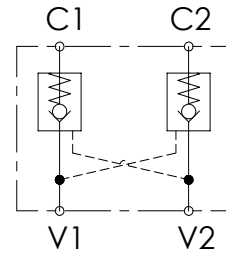

SPECIFICATIONS

Max. operating pressure:	350 bar (5000 psi)
Rated flow:	20 l/min (5 gpm)
Manifold:	Steel
Weight:	0,67 kg (1,48 lbs)
Contamination class to ISO 4406:	See technical spec.
MTTF _d :	150 - 1200 years: See technical spec.

NOTES

For other configurations/quick codes not available in this catalogue page please consult factory

CURVES

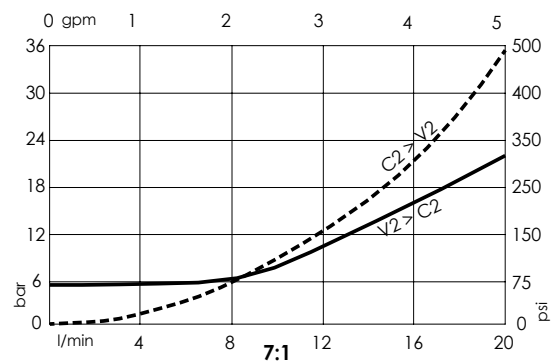
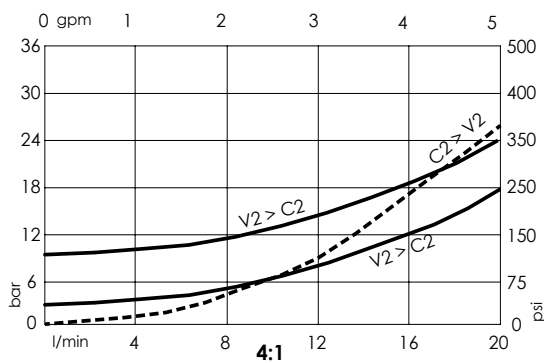

ORDERING CODES

Quick code	Description	Main ports size	Pilot ratio	Cracking pressure	O-ring on pilot piston
MC000174	MCDN-020-SLAS-04-G38-N003	V1,V2,C1,C2 : G 3/8"	4:1	3 bar (50 psi)	NO
MC000213	MCDN-020-SLAS-04-G38-N009	V1,V2,C1,C2 : G 3/8"	4:1	9 bar (125 psi)	NO
MC000212	MCDN-020-SLAS-07-G38-N005	V1,V2,C1,C2 : G 3/8"	7:1	5 bar (75 psi)	NO

Revision B1

PILOT OPERATED CHECK VALVE

MCDN-030-TLNS

DOUBLE ACTING

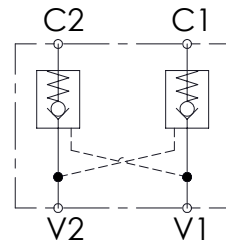
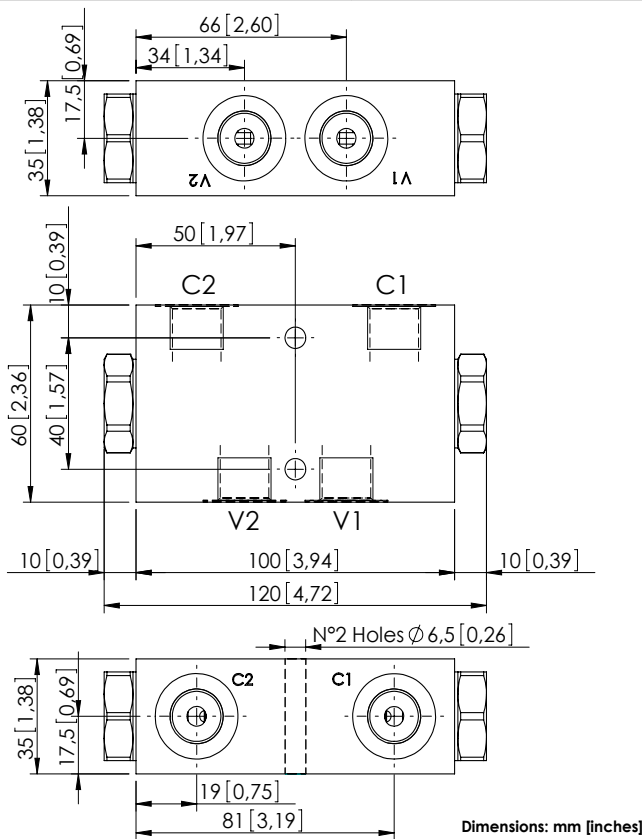

SPECIFICATIONS

Max. operating pressure:	350 bar (5000 psi)
Rated flow:	30 l/min (8 gpm)
Manifold:	Aluminium
Weight:	0,67 kg (1,48 lbs)
Contamination class to ISO 4406:	See technical spec.
MTF _a :	150 - 1200 years: See technical spec.

NOTES

For other configurations/quick codes not available in this catalogue page please consult factory

CURVES

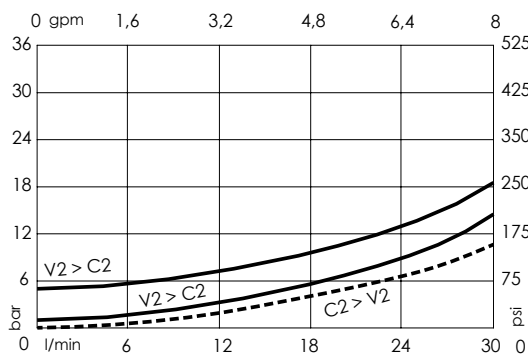

ORDERING CODES

Quick code	Description	Main ports size	Pilot ratio	Cracking pressure	O-ring on pilot piston
MC000002	MCDN-030-TLNS-07-G38-N001	V1,V2,C1,C2 : G 3/8"	7:1	1 bar (15 psi)	NO
MC000009	MCDN-030-TLNS-07-G38-N005	V1,V2,C1,C2 : G 3/8"	7:1	5 bar (75 psi)	NO
MC000010	MCDN-030-TLNC-07-G38-N005	V1,V2,C1,C2 : G 3/8"	7:1	5 bar (75 psi)	YES

PILOT OPERATED CHECK VALVE

MCDN-030-TBNS

DOUBLE ACTING
TWO FLANGED PORTS

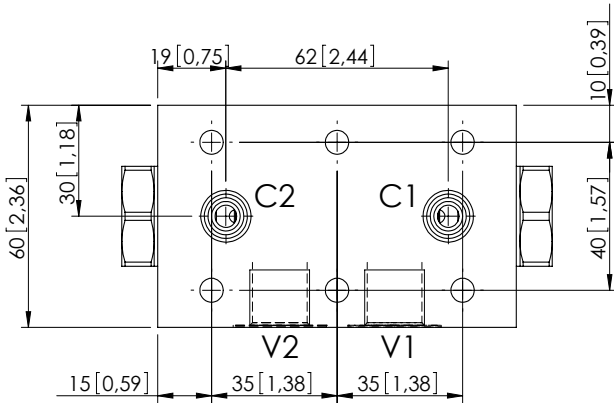
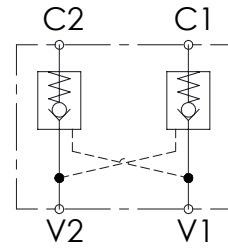
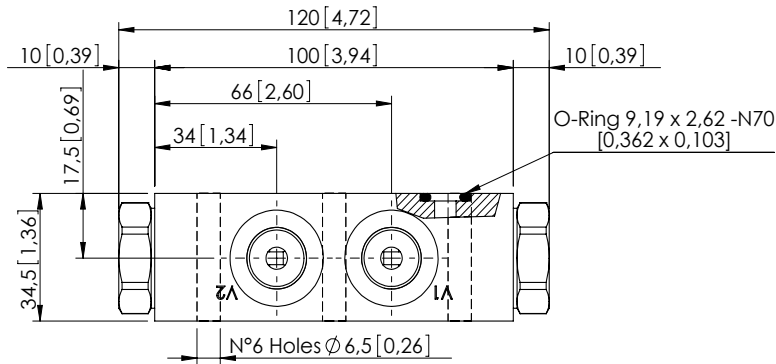

Dimensions: mm [inches]

SPECIFICATIONS

Max. operating pressure:	350 bar (5000 psi)
Rated flow:	30 l/min (8 gpm)
Manifold:	Aluminium
Weight:	0,67 kg (1,48 lbs)
Contamination class to ISO 4406:	See technical spec.
MTF _d :	150 - 1200 years: See technical spec.

NOTES

For other configurations/quick codes not available in this catalogue page please consult factory

CURVES

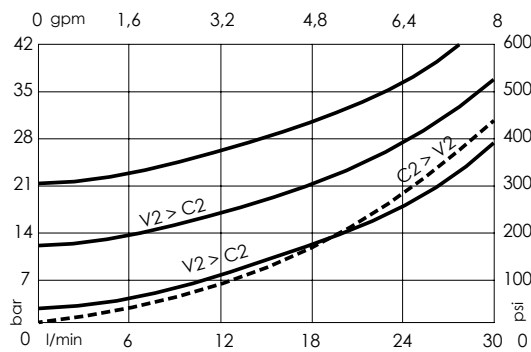

ORDERING CODES

Quick code	Description	Main ports size	Pilot ratio	Cracking pressure	O-ring on pilot piston
MC000005	MCDN-030-TBNS-07-G38-N001	V1,V2:G 3/8" C1,C2: \varnothing 6	7:1	1 bar (15 psi)	NO
MC000012	MCDN-030-TBNS-07-G38-N005	V1,V2:G 3/8" C1,C2: \varnothing 6	7:1	5 bar (75 psi)	NO
MC000020	MCDN-030-TBNC-07-G38-N005	V1,V2:G 3/8" C1,C2: \varnothing 6	7:1	5 bar (75 psi)	YES
MC000092	MCDN-030-LBNS-07-G38-N009	V1,V2:G 3/8" C1,C2: \varnothing 6	7:1	9 bar (125 psi)	NO
MC000195	MCDN-030-LBNC-07-G38-N009	V1,V2:G 3/8" C1,C2: \varnothing 6	7:1	9 bar (125 psi)	YES

PILOT OPERATED CHECK VALVE

MCDN-030-SBNS

DOUBLE ACTING
TWO FLANGED PORTS

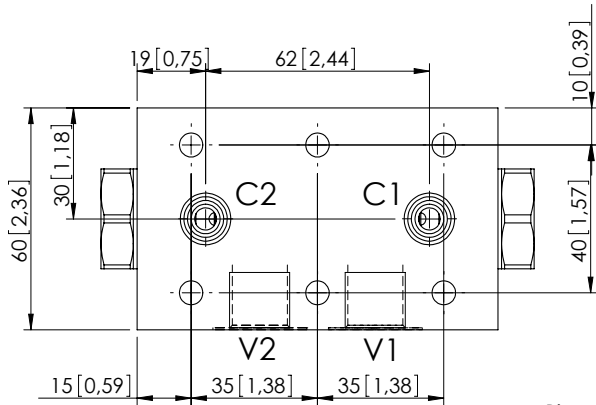
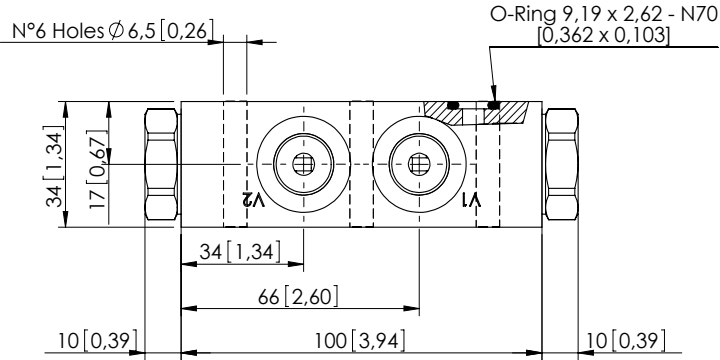

Dimensions: mm [inches]

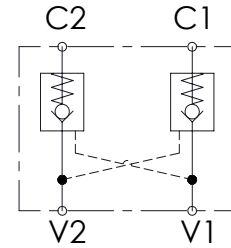

SPECIFICATIONS

Max. operating pressure:	350 bar (5000 psi)
Rated flow:	30 l/min (8 gpm)
Manifold:	Steel
Weight:	1,49 kg (3,29 lbs)
Contamination class to ISO 4406:	See technical spec.
MTF _d :	150 - 1200 years: See technical spec.

NOTES

For other configurations/quick codes not available in this catalogue page please consult factory

CURVES

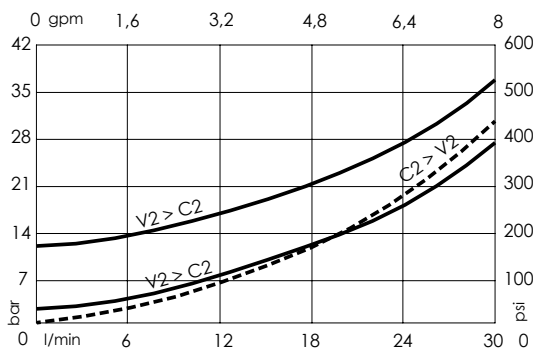

ORDERING CODES

Quick code	Description	Main ports size	Pilot ratio	Cracking pressure	O-ring on pilot piston
MC000036	MCDN-030-SBNS-07-G38-N005	V1,V2:G 3/8" C1,C2: Ø6	7:1	5 bar (75 psi)	NO
MC000037	MCDN-030-SBNC-07-G38-N005	V1,V2:G 3/8" C1,C2: Ø6	7:1	5 bar (75 psi)	YES
MC000038	MCDN-030-SBNS-07-G38-N001	V1,V2:G 3/8" C1,C2: Ø6	7:1	1 bar (15 psi)	NO

PILOT OPERATED CHECK VALVE

MCDN-060-TLNS

DOUBLE ACTING

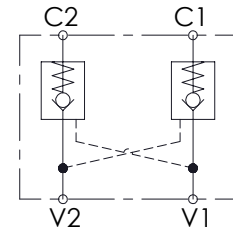
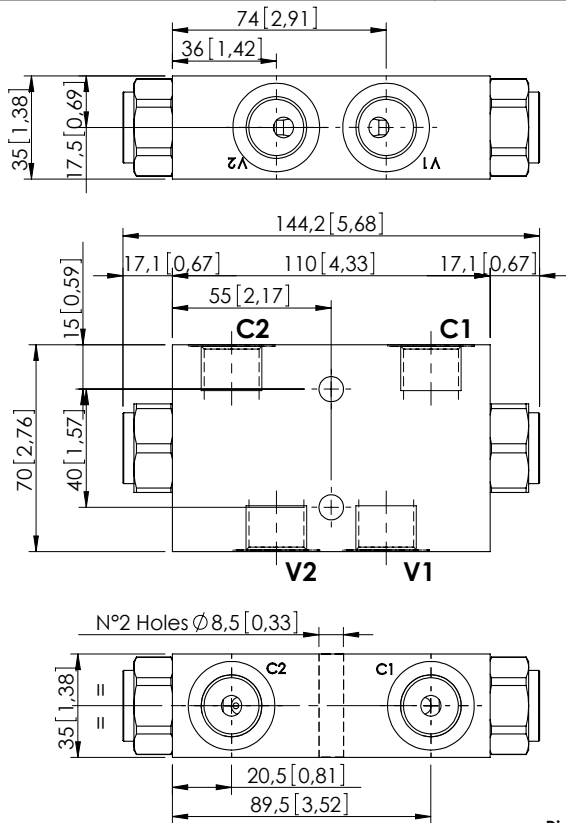

SPECIFICATIONS

Max. operating pressure:	350 bar (5000 psi)
Rated flow:	60 l/min (16 gpm)
Manifold:	Aluminium
Weight:	0,9 kg (1,98 lbs)
Contamination class to ISO 4406:	See technical spec.
MTTF _a :	150 - 1200 years: See technical spec.

NOTES

For other configurations/quick codes not available in this catalogue page please consult factory

CURVES

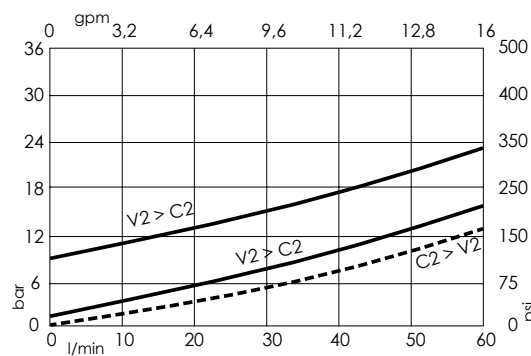

ORDERING CODES

Quick code	Description	Main ports size	Pilot ratio	Cracking pressure	O-ring on pilot piston
MC000042	MCDN-060-TLNS-03-G12-N001	V1,V2,C1,C2 : G1/2"	3:1	1 bar (15 psi)	NO
MC000040	MCDN-060-TLNS-03-G12-N008	V1,V2,C1,C2 : G1/2"	3:1	8 bar (100 psi)	NO
MC000041	MCDN-060-TLNC-03-G12-N008	V1,V2,C1,C2 : G1/2"	3:1	8 bar (100 psi)	YES

PILOT OPERATED CHECK VALVE

MCDN-060-TBNS

DOUBLE ACTING
TWO FLANGED PORTS

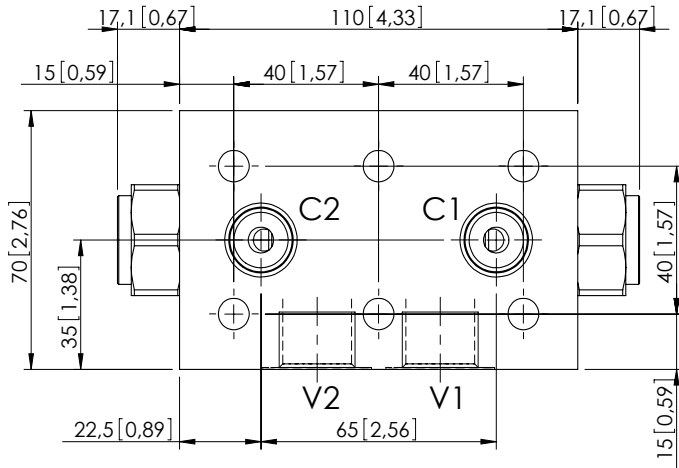
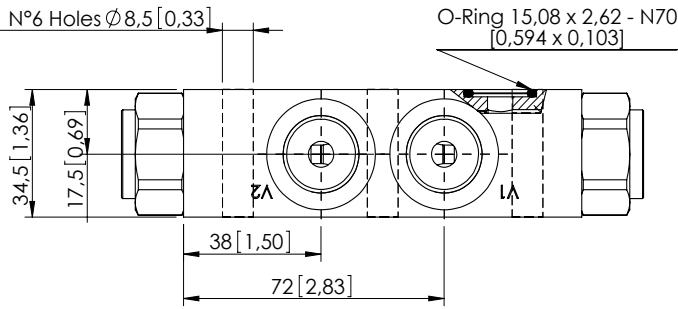

Dimensions: mm [inches]

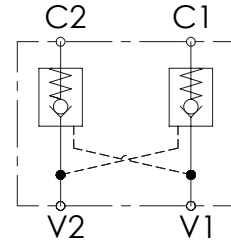

SPECIFICATIONS

Max. operating pressure:	350 bar (5000 psi)
Rated flow:	60 l/min (16 gpm)
Manifold:	Aluminium
Weight:	0,9 kg (1,98 lbs)
Contamination class to ISO 4406:	See technical spec.
MTTF _a :	150 - 1200 years: See technical spec.

NOTES

For other configurations/quick codes not available in this catalogue page please consult factory

CURVES

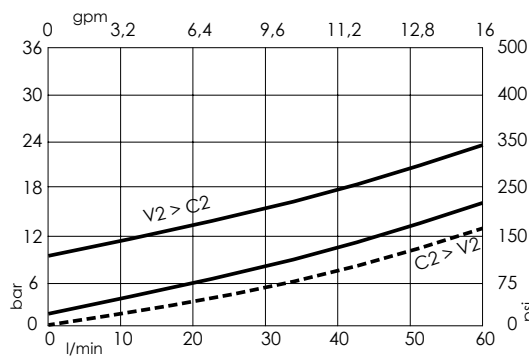

ORDERING CODES

Quick code	Description	Main ports size	Pilot ratio	Cracking pressure	O-ring on pilot piston
MC000029	MCDN-060-TBNS-03-G12-N001	V1,V2:G 1/2" C1,C2:Ø7	3:1	1 bar (15 psi)	NO
MC000027	MCDN-060-TBNS-03-G12-N008	V1,V2:G 1/2" C1,C2:Ø7	3:1	8 bar (100 psi)	NO
MC000028	MCDN-060-TBNC-03-G12-N008	V1,V2:G 1/2" C1,C2:Ø7	3:1	8 bar (100 psi)	YES
MC000026	MCDN-060-TBNS-06-G12-N001	V1,V2:G 1/2" C1,C2:Ø7	6:1	1 bar (15 psi)	NO
MC000025	MCDN-060-TBNS-06-G12-N008	V1,V2:G 1/2" C1,C2:Ø7	6:1	8 bar (100 psi)	NO
MC000022	MCDN-060-TBNC-06-G12-N008	V1,V2:G 1/2" C1,C2:Ø7	6:1	8 bar (100 psi)	YES

PILOT OPERATED CHECK VALVE

MCDN-100-LLNR

DOUBLE ACTING

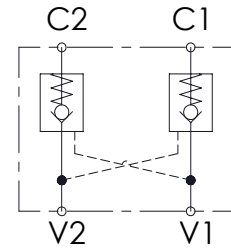
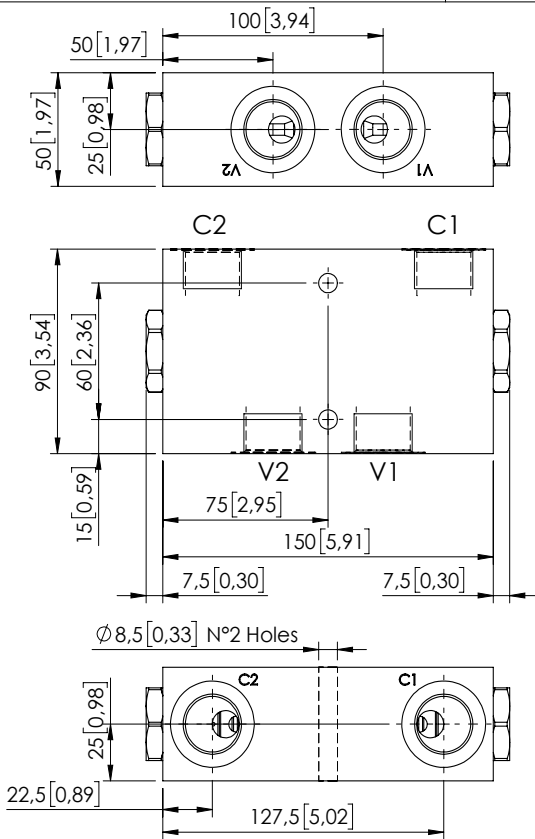

SPECIFICATIONS

Max. operating pressure:	350 bar (5000 psi)
Rated flow:	100 l/min (27 gpm)
Manifold:	Aluminium
Weight:	1,8 kg (3,97 lbs)
Contamination class to ISO 4406:	See technical spec.
MTF _a :	150 - 1200 years: See technical spec.

NOTES

For other configurations/quick codes not available in this catalogue page please consult factory

CURVES

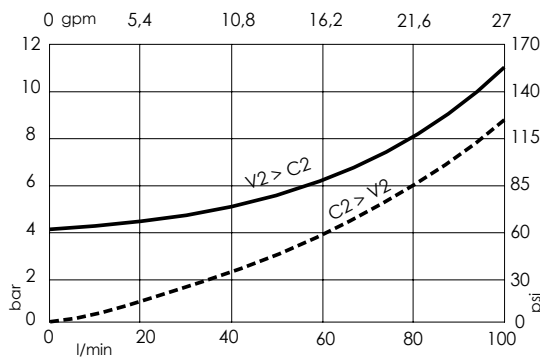

ORDERING CODES

Quick code	Description	Main ports size	Pilot ratio	Cracking pressure	O-ring on pilot piston
MC000144	MCDN-100-LLNR-04-G34-N004	V1,V2,C1,C2 : G3/4"	4:1	4 bar (50 psi)	NO