



ATLANTIC
Fluid Tech

**SECTION
2**

Pressure
Reducing
Valves

PRESSURE REDUCING VALVES

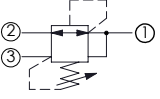
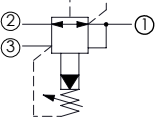
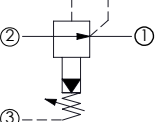
Hydraulic scheme	Valve description	Valve type	Rated flow l/min (gpm)	Max. pressure bar (psi)	Installation	Main port size or cavity type	Page
	CPRL-007-DNNR	Direct acting, reducing and relieving	5 (1,3)	350(5000)	Cartridge	VP000016	2.01. 010
	CPRL-030-DNNR	Direct acting, reducing and relieving	30 (8)	350(5000)	Cartridge	SAE-10-3N	2.01. 020
	CPRL-030-DNSR	Direct acting, reducing and relieving	30 (8)	350(5000)	Cartridge	SAE-10-3N	2.01. 030
	KPRL-030-DNNR	Pilot operated, reducing and relieving	30 (8)	210(3000)	In line	G3/8"	2.02. 060
	CPRL-060-PNNR	Pilot operated, reducing and relieving	60 (16)	350(5000)	Cartridge	SAE-10-3N	2.02. 040
	CPRL-140-PNNR	Pilot operated, reducing and relieving	140 (37)	350(5000)	Cartridge	SAE-12-3N	2.02. 050
	KPRL-060-DNNR	Pilot operated, reducing and relieving	60 (16)	250(3600)	In line	G3/8"	2.02. 060
	CPRR-060-PNNR	Pilot operated, reducing	60 (16)	350(5000)	Cartridge	SAE-10-3N	2.03. 070
	CPRR-140-PNNR	Pilot operated, reducing	140 (37)	350(5000)	Cartridge	SAE-12-3N	2.03. 080
	KPRR-140-PNNR	Pilot operated, reducing	140 (37)	250(3600)	In line	G1/2"	2.03. 090

PRESSURE REDUCING AND RELIEVING

CPRL-007-DNNR

DIRECT ACTING
SPOOL TYPE

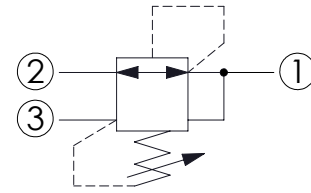
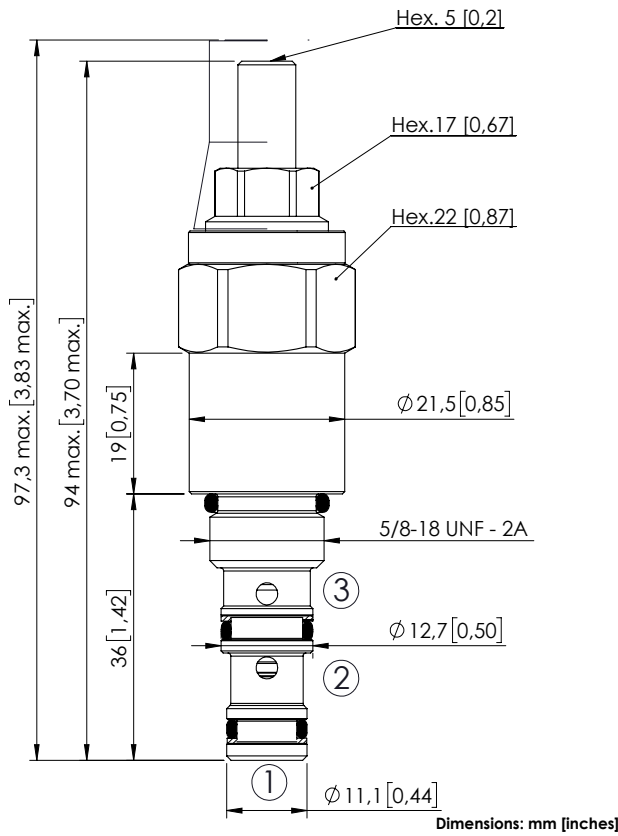

SPECIFICATIONS

Max. operating pressure:	350 bar (5000 psi)
Rated flow:	5 l/min (1,3 gpm)
Cavity:	VP000016
Weight:	0,14 kg (0,31 lbs)
Contamination class to ISO 4406:	See technical spec.
Seal kit:	RC700016
Installation torque:	25 - 30 Nm (18 - 22 ft-lb)
MTF _d :	150 - 1200 years: See technical spec.
Leakage:	35 cm ³ /min @ 50 bar 2,14 in ³ /min @ 700 psi

NOTES

For other configurations/quick codes not available in this catalogue page please consult factory

SEALING CAP



Ordering code:
AT000020

CURVES

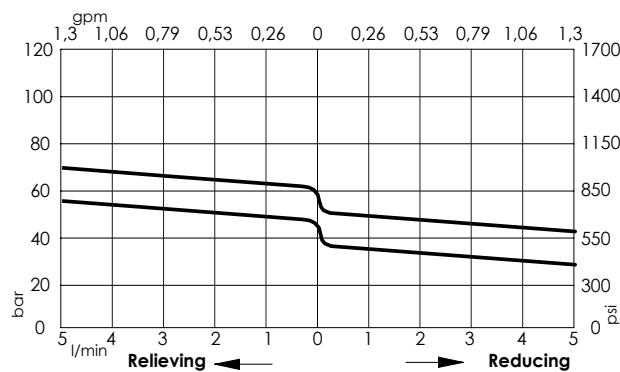

ORDERING CODES

Quick code	Description	Standard setting	Adjustment range	Pressure increase
CR000001	CPRL-007-DNNR-HN-016-N060	40 bar (600 psi)	10-60 bar (150-850 psi)	6 bar/turn (100 psi/turn)
CR000025	CPRL-007-DNNR-HN-016-N085	60 bar (850 psi)	25-85 bar (350-1200 psi)	9 bar/turn (150 psi/turn)

PRESSURE REDUCING AND RELIEVING

CPRL-030-DNNR

DIRECT ACTING
SPOOL TYPE

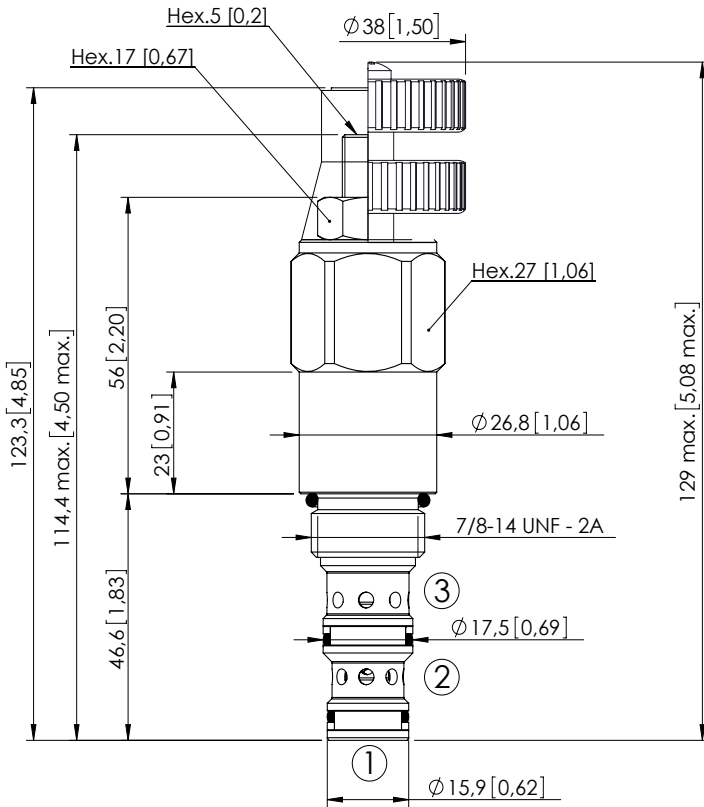

Dimensions: mm [inches]

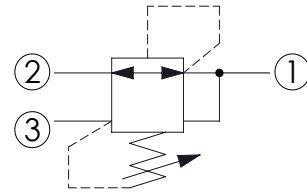

SPECIFICATIONS

Max. operating pressure:	350 bar (5000 psi)
Rated flow:	30 l/min (8 gpm)
Cavity:	SAE-10-3N
Weight:	0.28 kg (0.62 lbs)
Contamination class to ISO 4406:	See technical spec.
Seal kit:	RA700092
Installation torque:	55 - 62 Nm (41 - 46 ft-lb)
MTF _d :	150 - 1200 years: See technical spec.
Leakage:	50 cm ³ /min @ 50 bar 3.05 in ³ /min @ 700 psi

NOTES

For other configurations/quick codes not available in this catalogue page please consult factory

OPTIONS

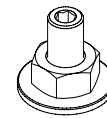

Adjustment with Screw

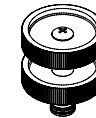

Adjustment with Handknob



Ordering code: AT000022

CURVES

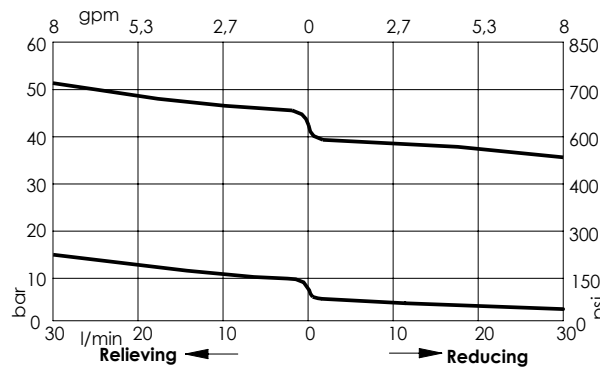

ORDERING CODES

Quick code	Description	Standard setting	Adjustment range	Pressure increase	Options
CR000002	CPRL-030-DNNR-HN-S10-N050	35 bar (500 psi)	10-50 bar (150-750 psi)	7 bar/turn (100 psi/turn)	Adjustment with Screw
CR000008	CPRL-030-DNNR-VN-S10-N050	35 bar (500 psi)	10-50 bar (150-750 psi)	7 bar/turn (100 psi/turn)	Adjustment with Handknob
CR000011	CPRL-030-DNNR-HN-S10-N015	5 bar (75 psi)	1.5-15 bar (25-200 psi)	1 bar/turn (15 psi/turn)	Adjustment with Screw
CR000012	CPRL-030-DNNR-VN-S10-N015	5 bar (75 psi)	1.5-15 bar (25-200 psi)	1 bar/turn (15 psi/turn)	Adjustment with Handknob

PRESSURE REDUCING AND RELIEVING

CPRL-030-DNSR

DIRECT ACTING
SPOOL TYPE
WITH DAMPING

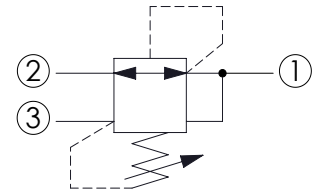
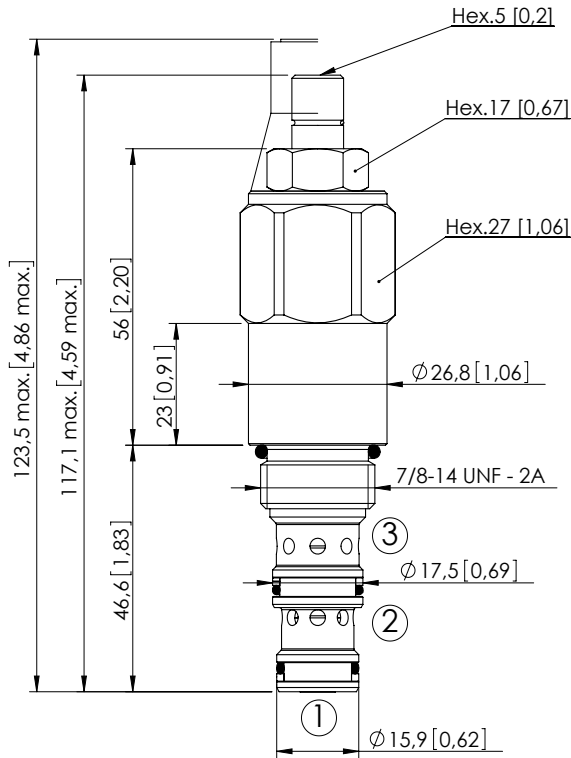

SPECIFICATIONS

Max. operating pressure:	350 bar (5000 psi)
Rated flow:	30 l/min (8 gpm)
Cavity:	SAE-10-3N
Weight:	0.29 kg (0,64 lbs)
Contamination class to ISO 4406:	See technical spec.
Seal kit:	RA700092
Installation torque:	55 - 62 Nm (41 - 46 ft-lb)
MTTF _d :	150 - 1200 years: See technical spec.
Leakage:	50 cm ³ /min @ 50 bar 3,05 in ³ /min @ 700 psi

Dimensions: mm [inches]

NOTES

For other configurations/quick codes not available in this catalogue page please consult factory

OPTIONS

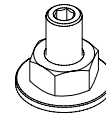

Adjustment with Screw

SEALING CAP



Ordering code:
AT000021

CURVES

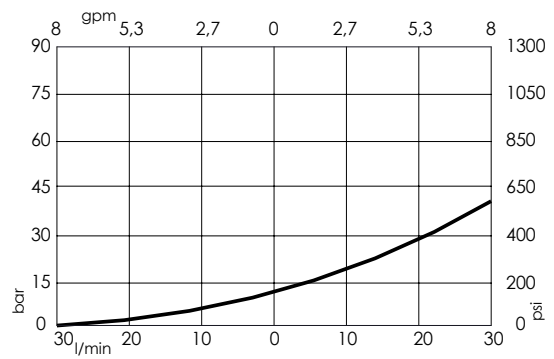
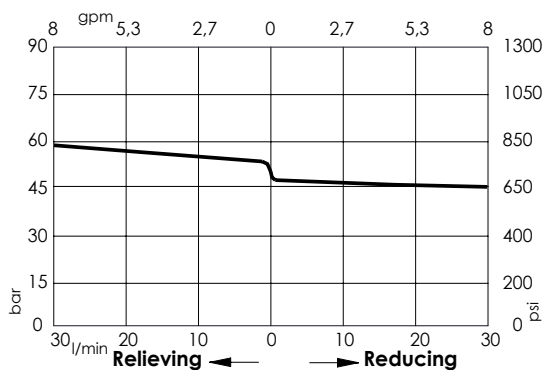

ORDERING CODES

Quick code	Description	Standard setting	Adjustment range	Pressure increase	Options
CR000038	CPRL-030-DNSR-HN-S10-N080	50 bar (700 psi)	20-75 bar (300-1100 psi)	11 bar/turn (150 psi/turn)	Adjustment with Screw
CR000056	CPRL-030-DNSR-HN-S10-N040	20 bar (300 psi)	10-35 bar (150-500 psi)	5,3 bar/turn (75 psi/turn)	Adjustment with Screw

PRESSURE REDUCING AND RELIEVING

CPRL-060-PNNR

PILOT OPERATED
SPOOL TYPE

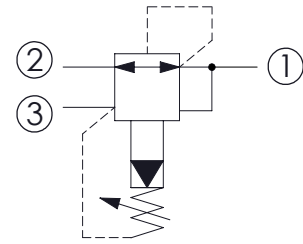
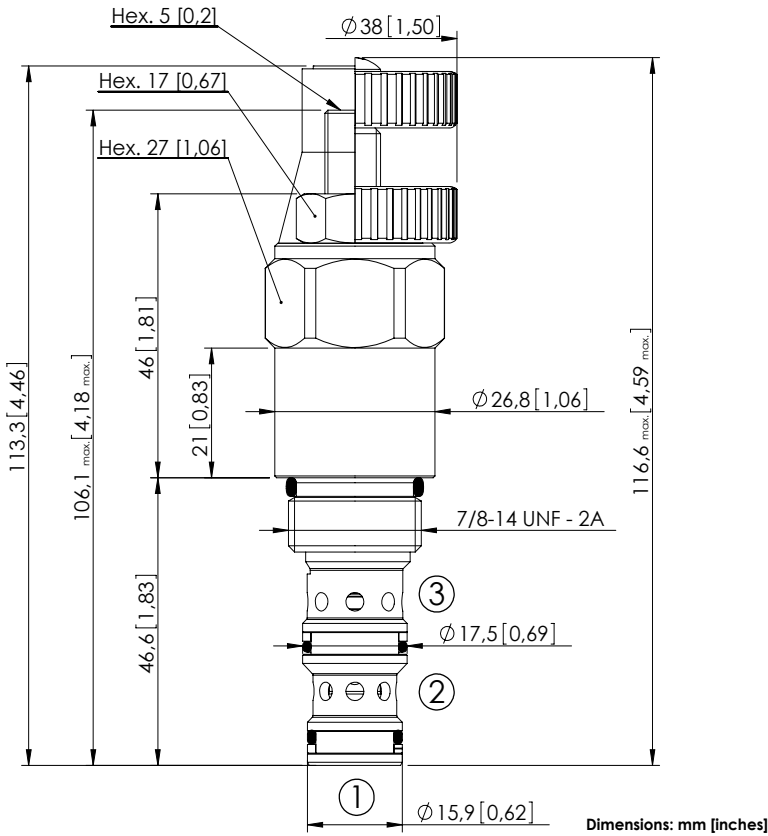

SPECIFICATIONS

Max. operating pressure:	350 bar (5000 psi)
Rated flow:	60 l/min (16 gpm)
Cavity:	SAE-10-3N
Weight:	0,26 kg (0,57 lbs)
Contamination class to ISO 4406:	See technical spec.
Seal kit:	RA700092
Installation torque:	55 - 62 Nm (41 - 46 ft-lb)
MTF _d :	150 - 1200 years: See technical spec.

NOTES

For other configurations/quick codes not available in this catalogue page please consult factory

OPTIONS

SEALING CAP

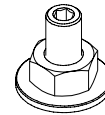

Adjustment with Screw



Adjustment with Handknob



Ordering code: AT000022

CURVES

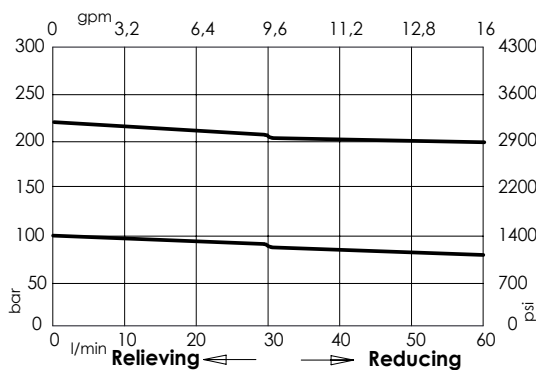

ORDERING CODES

Quick code	Description	Standard setting	Adjustment range	Pressure increase	Options
CR000006	CPRL-060-PNNR-HN-S10-N300	200 bar (2900 psi)	70-350 bar (1000-5000 psi)	114 bar/turn (1600 psi/turn)	Adjustment with Screw
CR000007	CPRL-060-PNNR-VN-S10-N300	200 bar (2900 psi)	70-350 bar (1000-5000 psi)	114 bar/turn (1600 psi/turn)	Adjustment with Handknob
CR000009	CPRL-060-PNNR-HN-S10-N100	80 bar (1200 psi)	20-110 bar (300-1600 psi)	37 bar/turn (550 psi/turn)	Adjustment with Screw
CR000010	CPRL-060-PNNR-VN-S10-N100	80 bar (1200 psi)	20-110 bar (300-1600 psi)	37 bar/turn (550 psi/turn)	Adjustment with Handknob

PRESSURE REDUCING AND RELIEVING

CPRL-140-PNNR

PILOT OPERATED
SPOOL TYPE

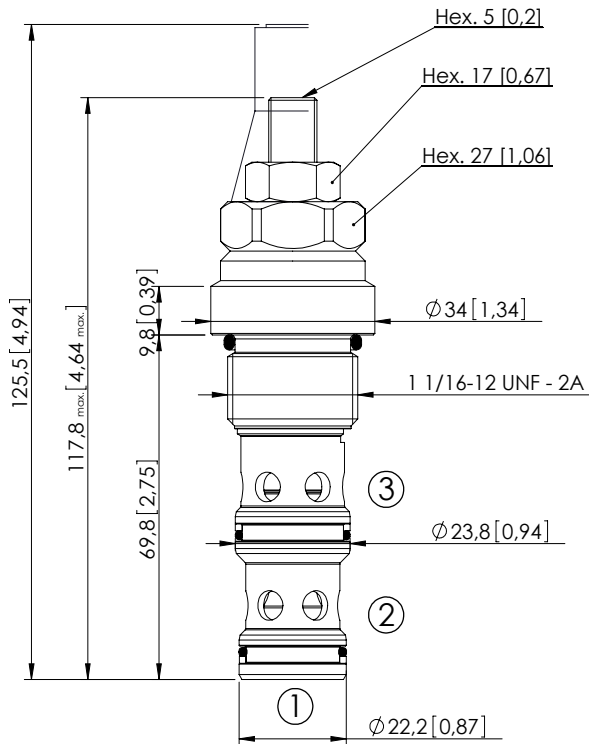

Dimensions: mm [inches]

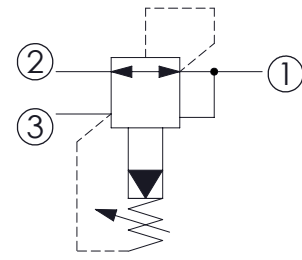

SPECIFICATIONS

Max. operating pressure:	350 bar (5000 psi)
Rated flow:	140 l/min (37 gpm)
Cavity:	SAE-12-3N
Weight:	0,34 kg (0,75 lbs)
Contamination class to ISO 4406:	See technical spec.
Seal kit:	RA700093
Installation torque:	80 - 95 Nm (59 - 70 ft-lb)
MTF _a :	150 - 1200 years: See technical spec.

NOTES

For other configurations/quick codes not available in this catalogue page please consult factory

OPTIONS

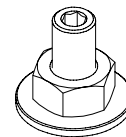

Adjustment with Screw

SEALING CAP



Ordering code:
AT000022

CURVES

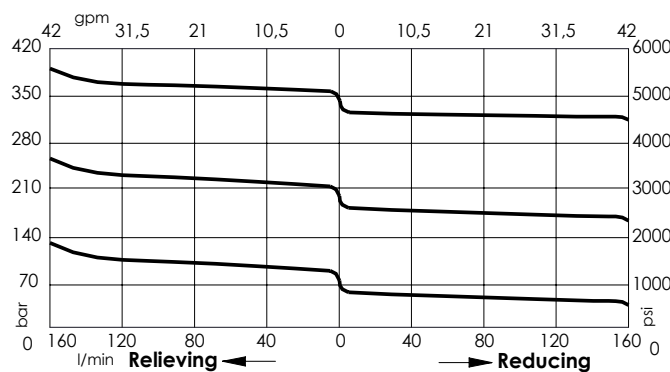

ORDERING CODES

Quick code	Description	Standard setting	Adjustment range	Pressure increase	Options
CR000020	CPRL-140-PNNR-HN-S12-N350	300 bar (4300 psi)	140-350 bar (2000-5000 psi)	114 bar/turn (1600 psi/turn)	Adjustment with Screw
CR000019	CPRL-140-PNNR-HN-S12-N200	200 bar (2900 psi)	70-250 bar (1000-3600 psi)	69 bar/turn (1000 psi/turn)	Adjustment with Screw
CR000018	CPRL-140-PNNR-HN-S12-N100	100 bar (1400 psi)	10-140 bar (150-2000 psi)	37 bar/turn (550 psi/turn)	Adjustment with Screw

PRESSURE REDUCING AND RELIEVING IN BODY

KPRL-030-DNNR

DIRECT/PILOT ACTING
SPOOL TYPE

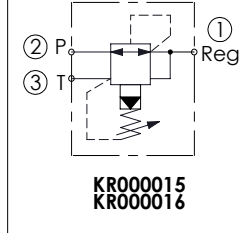
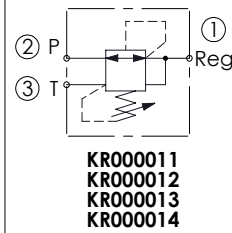
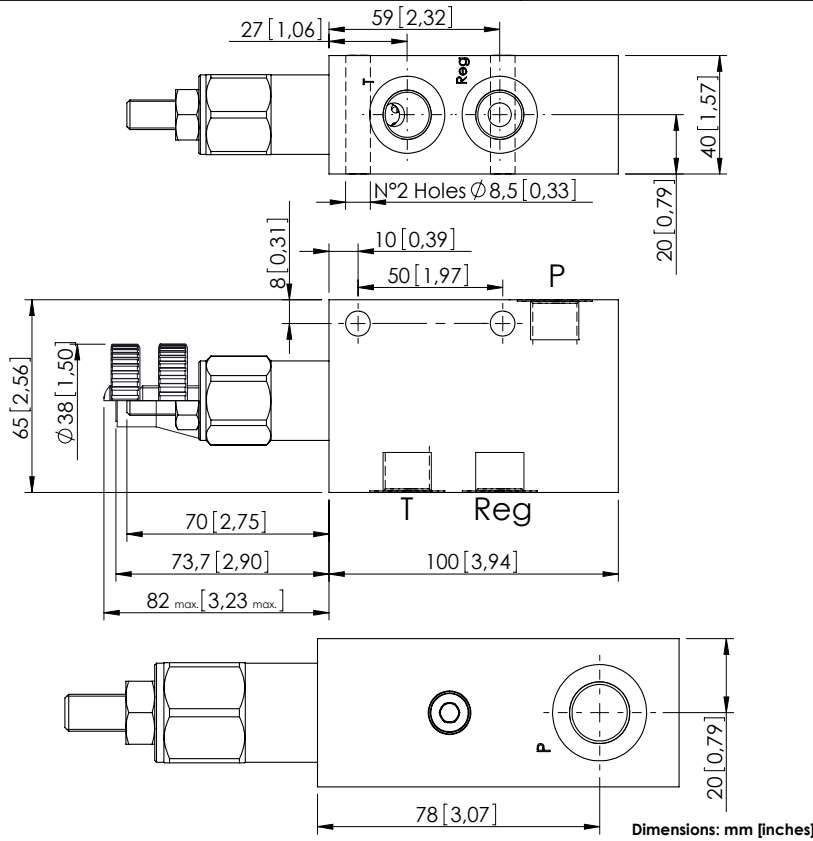

SPECIFICATIONS

Max. operating pressure:	250 bar (3600 psi)
Rated flow:	30 - 60 l/min (8 - 16 gpm)
Cavity:	SAE-10-3N
Weight:	0,9 kg (1,98 lbs)
Leakage:	50 cm ³ /min @ 50 bar 3,05 in ³ /min @ 700 psi
Manifold:	Aluminium
Contamination class to ISO 4406:	See technical spec.
MTF _a :	150 - 1200 years: See technical spec.

NOTES

For other configurations/quick codes not available in this catalogue page please consult factory

OPTIONS

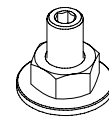

Adjustment with Screw



Adjustment with Handknob



Ordering code:
AT000022

CURVES

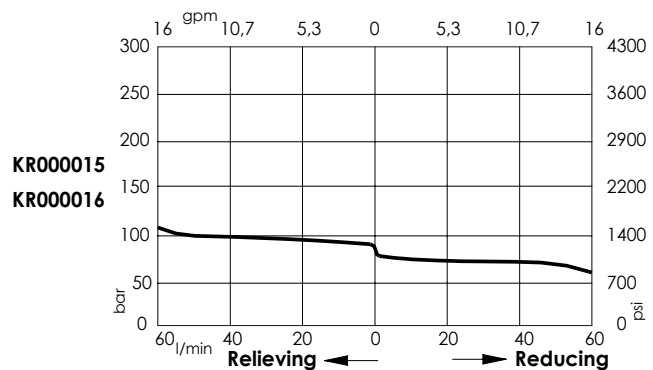
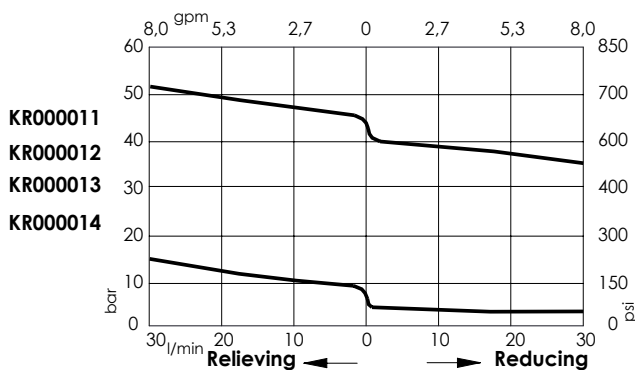

ORDERING CODES

Quick code	Description	Ports	Standard setting	Adjustment range	Pressure increase	Options
KR000011	KPRL-030-DNNR-HN-G38-N250	P,T,Reg: G 3/8"	5 bar (75 psi)	1.5-15 bar (25-75 psi)	1.6 bar/turn (25 psi/turn)	Adjustment with Screw
KR000012	KPRL-030-DNNR-VN-G38-N250	P,T,Reg: G 3/8"	5 bar (75 psi)	1.5-15 bar (25-75 psi)	1.6 bar/turn (25 psi/turn)	Adjustment with Handknob
KR000013	KPRL-030-DNNR-HN-G38-N250	P,T,Reg: G 3/8"	35 bar (500 psi)	10-50 bar (150-700 psi)	7 bar/turn (100 psi/turn)	Adjustment with Screw
KR000014	KPRL-030-DNNR-VN-G38-N250	P,T,Reg: G 3/8"	35 bar (500 psi)	10-50 bar (150-700 psi)	7 bar/turn (100 psi/turn)	Adjustment with Handknob
KR000015	KPRL-060-PNNR-HN-G38-N250	P,T,Reg: G 3/8"	80 bar (1100 psi)	20-110 bar (300-1600 psi)	37 bar/turn (550 psi/turn)	Adjustment with Screw
KR000016	KPRL-060-PNNR-VN-G38-N250	P,T,Reg: G 3/8"	80 bar (1100 psi)	20-110 bar (300-1600 psi)	37 bar/turn (550 psi/turn)	Adjustment with Handknob

PRESSURE REDUCING AND RELIEVING

CPRR-060-PNNR

PILOT OPERATED
SPOOL TYPE

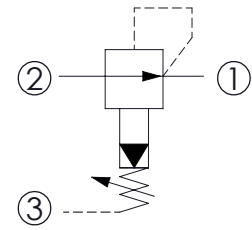
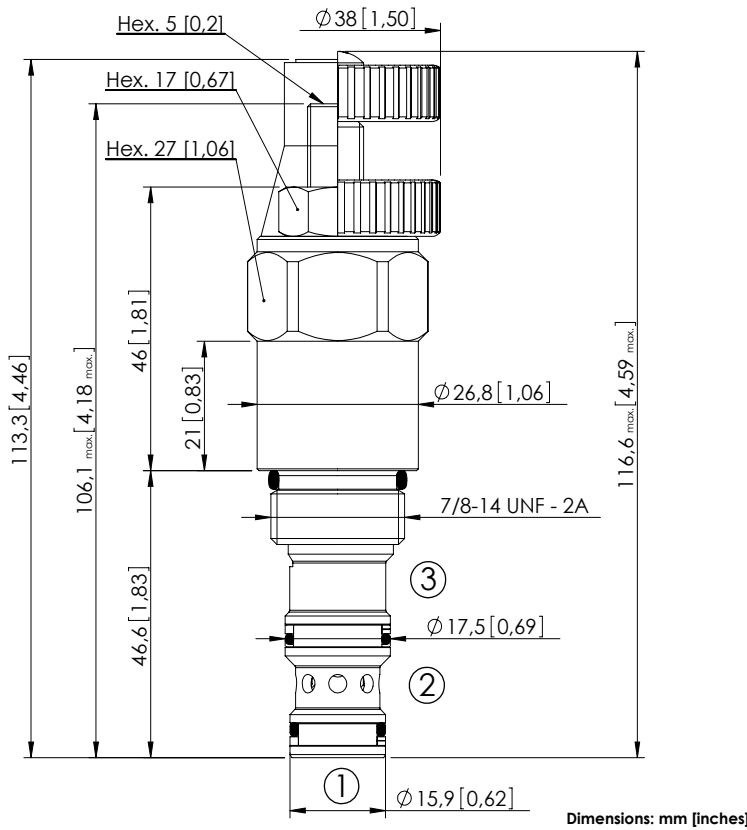

SPECIFICATIONS

Max. operating pressure:	350 bar (5000 psi)
Rated flow:	60 l/min (16 gpm)
Cavity:	SAE-10-3N
Weight:	0,26 kg (0,57 lbs)
Contamination class to ISO 4406:	See technical spec.
Seal kit:	RA700092
Installation torque:	55 - 62 Nm (41 - 46 ft-lb)
MTF _d :	150 - 1200 years: See technical spec.

NOTES

For other configurations/quick codes not available in this catalogue page please consult factory

OPTIONS

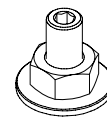

Adjustment with Screw



Adjustment with Handknob



Ordering code: AT000022

CURVES

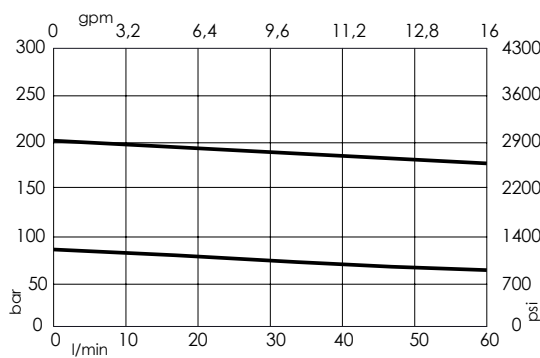

ORDERING CODES

Quick code	Description	Standard setting	Adjustment range	Pressure increase	Options
CR000022	CPRR-060-PNNR-HN-S10-N300	200 bar (2900 psi)	70-350 bar (1000-5000 psi)	114 bar/turn (1600 psi/turn)	Adjustment with Screw
CR000023	CPRR-060-PNNR-VN-S10-N300	200 bar (2900 psi)	70-350 bar (1000-5000 psi)	114 bar/turn (1600 psi/turn)	Adjustment with Handknob
CR000024	CPRR-060-PNNR-HN-S10-N100	80 bar (1100 psi)	20-110 bar (300-1600 psi)	37 bar/turn (550 psi/turn)	Adjustment with Screw
CR000021	CPRR-060-PNNR-VN-S10-N100	80 bar (1100 psi)	20-110 bar (300-1600 psi)	37 bar/turn (550 psi/turn)	Adjustment with Handknob

PRESSURE REDUCING AND RELIEVING

CPRR-140-PNNR

PILOT OPERATED
SPOOL TYPE

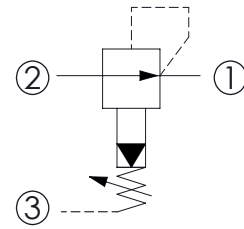
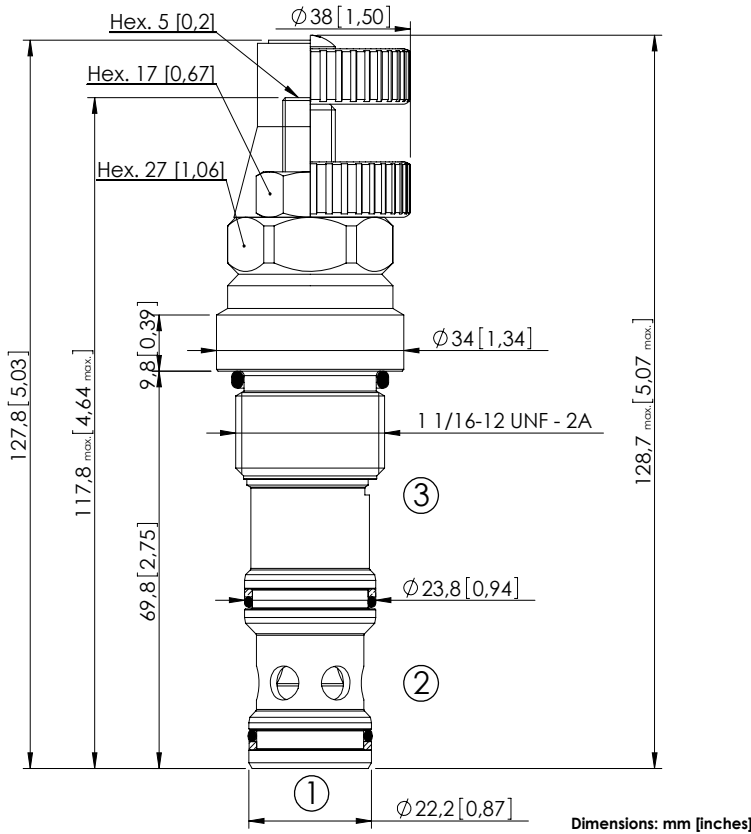

SPECIFICATIONS

Max. operating pressure:	350 bar (5000 psi)
Rated flow:	140 l/min (37 gpm)
Cavity:	SAE-12-3N
Weight:	0,35 kg (0,77 lbs)
Contamination class to ISO 4406:	See technical spec.
Seal kit:	RA700093
Installation torque:	80 - 95 Nm (59 - 70 ft-lb)
MTF _a :	150 - 1200 years: See technical spec.

NOTES

For other configurations/quick codes not available in this catalogue page please consult factory

OPTIONS

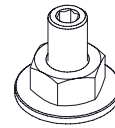

Adjustment with Screw



Handknob and locknut

SEALING CAP



Ordering code: AT000022

CURVES

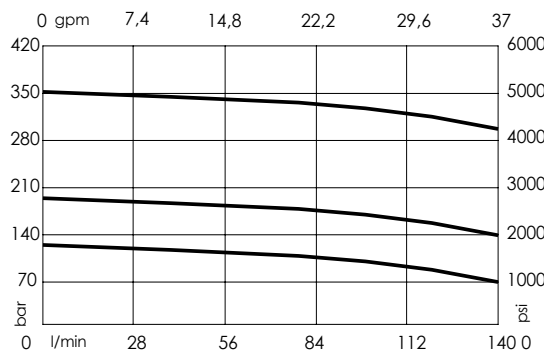

ORDERING CODES

Quick code	Description	Standard setting	Adjustment range	Pressure increase	Options
CR000017	CPRR-140-PNNR-HN-S12-N350	300 bar (4300 psi)	140-350 bar (2000-5000 psi)	114 bar/turn (1600 psi/turn)	Adjustment with Screw
CR000030	CPRR-140-PNNR-VN-S12-N350	300 bar (4300 psi)	140-350 bar (2000-5000 psi)	114 bar/turn (1600 psi/turn)	Adjustment with Handknob
CR000016	CPRR-140-PNNR-HN-S12-N200	200 bar (2900 psi)	70-210 bar (1000-3000 psi)	69 bar/turn (1000 psi/turn)	Adjustment with Screw
CR000027	CPRR-140-PNNR-VN-S12-N200	200 bar (2900 psi)	70-210 bar (1000-3000 psi)	69 bar/turn (1000 psi/turn)	Adjustment with Handknob
CR000015	CPRR-140-PNNR-HN-S12-N100	100 bar (1400 psi)	10-120 bar (150-1700 psi)	37 bar/turn (550 psi/turn)	Adjustment with Screw
CR000031	CPRR-140-PNNR-VN-S12-N100	100 bar (1400 psi)	10-120 bar (150-1700 psi)	37 bar/turn (550 psi/turn)	Adjustment with Handknob

PRESSURE REDUCING

KPRR-140-PNNR

PILOT OPERATED
SPOOL TYPE

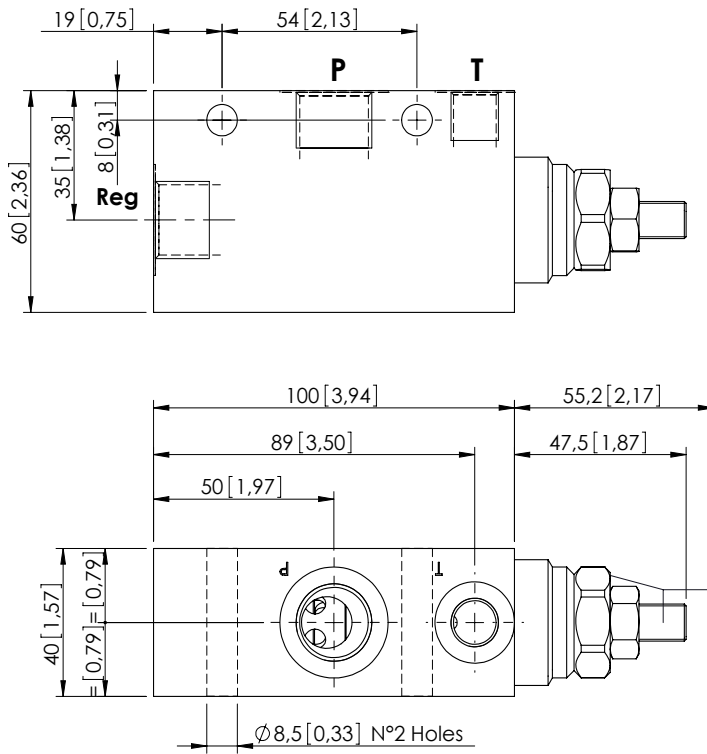

Dimensions: mm [inches]

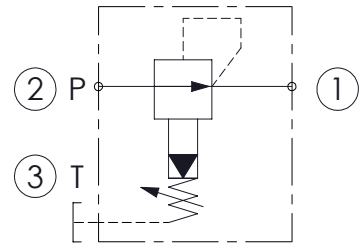

SPECIFICATIONS

Max. operating pressure:	250 bar (3600 psi)
Rated flow:	140 l/min (37 gpm)
Cavity:	SAE-12-3N
Weight:	0,8 kg (1,76 lbs)
Manifold:	Aluminium
Contamination class to ISO 4406:	See technical spec.
MTF _d :	150 - 1200 years: See technical spec.

NOTES

For other configurations/quick codes not available in this catalogue page please consult factory

OPTIONS

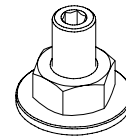

Adjustment with Screw

SEALING CAP

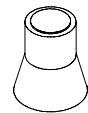

Ordering code: AT000022

CURVES

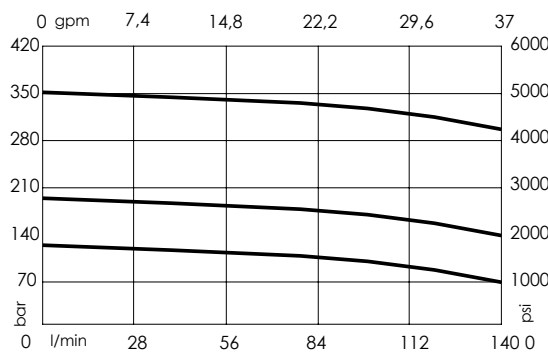

ORDERING CODES

Quick code	Description	Ports	Standard setting	Adjustment range	Pressure increase	Options
KR000017	KPRR-140-PNNR-HN-G12-N250	P-Reg: G 1/2" T: G 1/4"	250 bar (3600 psi)	140-250 bar (2000-5000 psi)	114 bar/turn (1600 psi/turn)	Adjustment with Screw
KR000019	KPRR-140-PNNR-HN-G12-N200	P-Reg: G 1/2" T: G 1/4"	200 bar (2900 psi)	70-210 bar (1000-3000 psi)	69 bar/turn (950 psi/turn)	Adjustment with Screw
KR000018	KPRR-140-PNNR-HN-G12-N100	P-Reg: G 1/2" T: G 1/4"	100 bar (1400 psi)	10-120 bar (150-1700 psi)	37 bar/turn (500 psi/turn)	Adjustment with Screw