



ATLANTIC
Fluid Tech

**SECTION
12**

Flow Dividers
and
Combiners

FLOW DIVIDERS AND COMBINERS

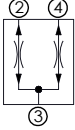
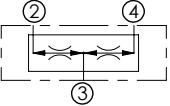
Hydraulic scheme	Valve description	Valve type	Rated flow l/min (gpm)	Max. pressure bar (psi)	Installation	Main port size or cavity type	Page
	CFDT-055-BRAR	Spool type, divider and combiner	55 (15)	350 (5000)	Cartridge	SAE-10-4N	12.01.010
	CFDT-160-BFRR	Spool type, divider and combiner	160 (43)	350 (5000)	Cartridge	SAE-16-4N	12.01.020
	MFDT-040-BFTR	Spool type, divider and combiner	40 (11)	210 (3000)	In line	G 3/8" - G 1/2"	12.02.030
	MFDT-150-BFLR	Spool type, divider and combiner	150 (40)	210 (3000)	In line	G 1" - G 3/4"	12.02.040
	KFDT-055-BFAR	Spool type, divider and combiner	55 (15)	210 (3000)	In line	G 1/4" - G 3/8" - G 1/2"	12.02.050

FLOW DIVIDER AND COMBINER

CFDT-055-BFRR

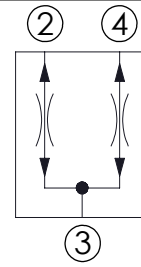
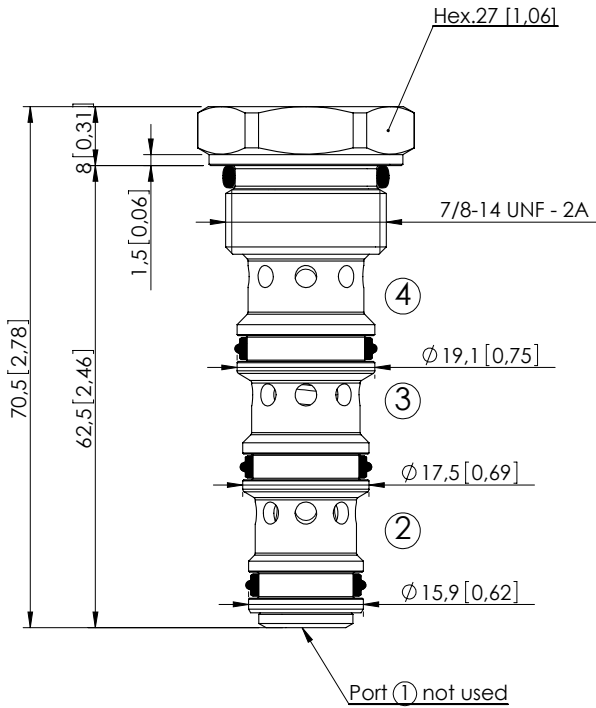

SPECIFICATIONS

Max. operating pressure:	350 bar (5000 psi)
Division or combination:	50 %- 50 %
Cavity:	SAE-10-4N-3P
Weight:	0,13 kg (0,29 lbs)
Seal kit:	RB700102
Installation torque:	50 - 57 Nm (37 - 42 ft-lb)
Contamination class to ISO 4406:	See technical spec.
MTF _a :	150 - 1200 years: See technical spec.

Dimensions: mm [inches]

NOTES

Flow divider accuracy: $\pm 7/8\%$ between 40-100% of max. input flow.
 Other dividing ratios available.
 For other configurations/quick codes not available in this catalogue page please consult factory

CURVES

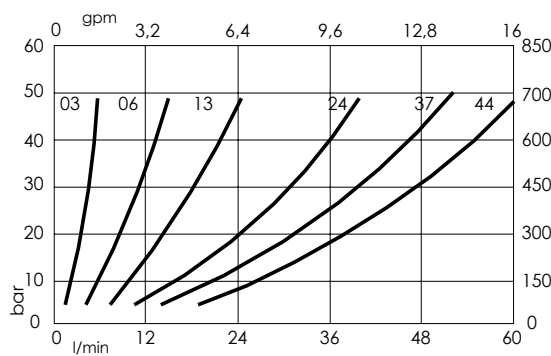

ORDERING CODES

Quick code	Description	Inlet range flow	
CF000047	CFDT-055-BFRR-03-S10-N350	1,2-3 l/min (0,3-0,8 gpm)	
CF000048	CFDT-055-BFRR-06-S10-N350	3-6 l/min (0,8-1,6 gpm)	
CF000049	CFDT-055-BFRR-13-S10-N350	6-13 l/min (1,6-3,4 gpm)	
CF000050	CFDT-055-BFRR-24-S10-N350	10-24 l/min (2,6-6,3 gpm)	
CF000001	CFDT-055-BFRR-37-S10-N350	15-37 l/min (3,9-9,8 gpm)	
CF000051	CFDT-055-BFRR-44-S10-N350	18-44 l/min (4,8-11,6 gpm)	

FLOW DIVIDER AND COMBINER

CFDT-160-BFRR

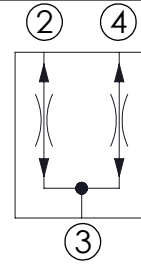
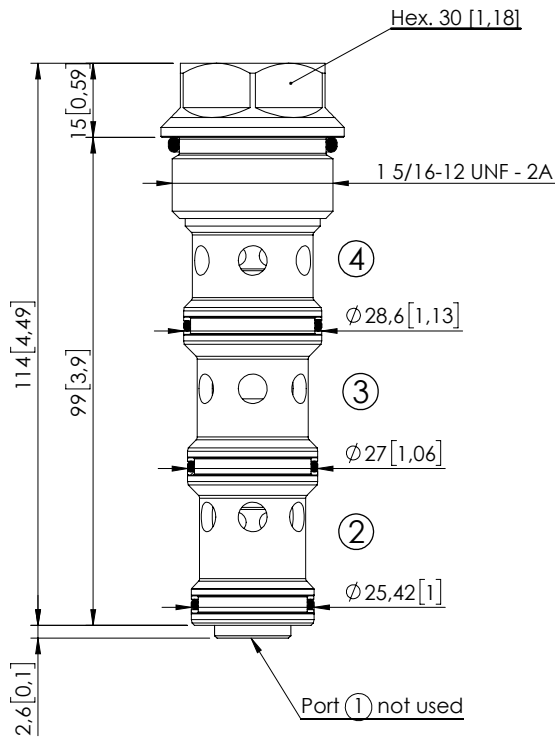

SPECIFICATIONS

Max. operating pressure:	350 bar (5000 psi)
Division or combination:	50 %- 50 %
Cavity:	SAE-16-4N
Weight:	0,36 kg (0,79 lbs)
Seal kit:	RB700104
Installation torque:	118 - 132 Nm (87 - 97 ft-lb)
Contamination class to ISO 4406:	See technical spec.
MTTF _d :	150 - 1200 years: See technical spec.

Dimensions: mm [inches]

NOTES

Flow divider accuracy: $\pm 7/8\%$ between 40-100% of max. input flow.
 Other dividing ratios available.
 For other configurations/quick codes not available in this catalogue page please consult factory

CURVES

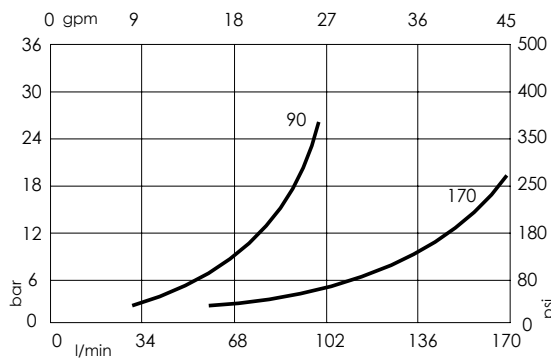

ORDERING CODES

Quick code	Description	Inlet range flow	
CF000364	CFDT-160-BFRR-90-S16-N350	30-90 l/min (8-24 gpm)	
CF000370	CFDT-160-BFRR-170-S16-N350	50-170 l/min (13-45 gpm)	

FLOW DIVIDER AND COMBINER

MFDT-040-BFTR

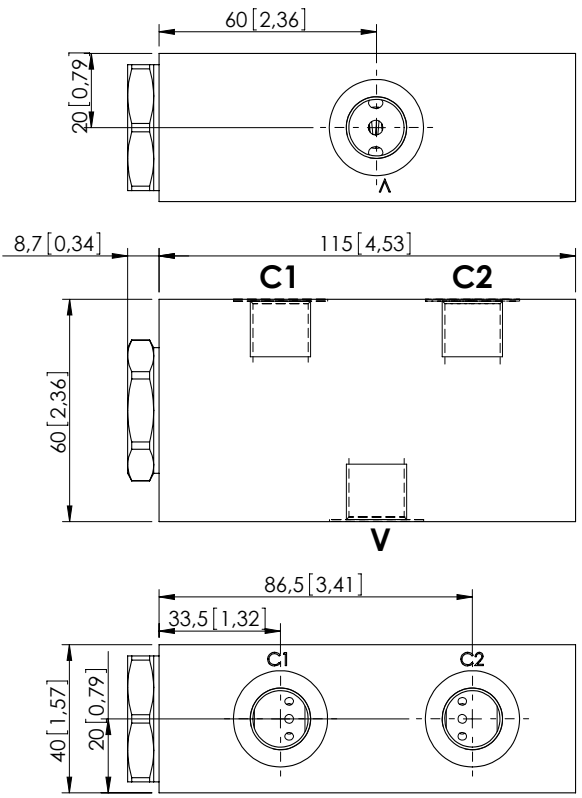

Dimensions: mm [inches]

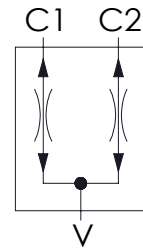

SPECIFICATIONS

Max. operating pressure:	210 bar (3000 psi)
Division or combination:	50 % - 50 %
Manifold:	Aluminium
Weight:	0,88 kg (1,94 lbs)
Cavity:	VP000242
Contamination class to ISO 4406:	See technical spec.
MTTF:	150 - 1200 years: See technical spec.

NOTES

Flow divider accuracy: $\pm 7/8\%$ between 40-100% of max. input flow.

For other configurations/quick codes not available in this catalogue page please consult factory

CURVES

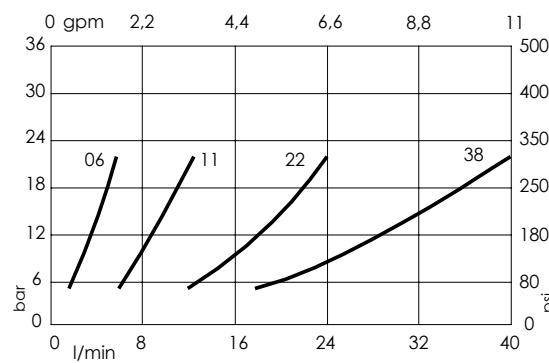

ORDERING CODES

Quick code	Description	Main ports size	Inlet range flow
MF000076	MFDT-040-BFTR-06-G38-N210	V:G3/8" ; C1,C2:G 3/8"	2,8 - 5,8 l/min (0,7-1,5 gpm)
MF000077	MFDT-040-BFTR-11-G38-N210	V:G3/8" ; C1,C2:G 3/8"	6,5 - 11 l/min (2-3 gpm)
MF000078	MFDT-040-BFTR-22-G38-N210	V:G3/8" ; C1,C2:G 3/8"	13 - 22 l/min (3,5-6 gpm)
MF000075	MFDT-040-BFTR-38-G38-N210	V:G3/8" ; C1,C2:G 3/8"	25 - 38 l/min (7-10 gpm)
MF000080	MFDT-040-BFTR-06-G12-N210	V:G1/2" ; C1,C2:G 3/8"	2,8 - 5,8 l/min (0,7-1,5 gpm)
MF000081	MFDT-040-BFTR-11-G12-N210	V:G1/2" ; C1,C2:G 3/8"	6,5 - 11 l/min (2-3 gpm)
MF000082	MFDT-040-BFTR-22-G12-N210	V:G1/2" ; C1,C2:G 3/8"	13 - 22 l/min (3,6-6 gpm)
MF000079	MFDT-040-BFTR-38-G12-N210	V:G1/2" ; C1,C2:G 3/8"	25 - 38 l/min (7-10 gpm)

FLOW DIVIDER AND COMBINER

MFDT-150-BFLR

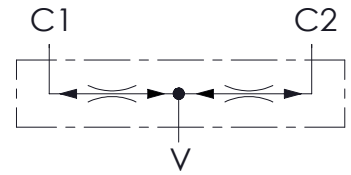
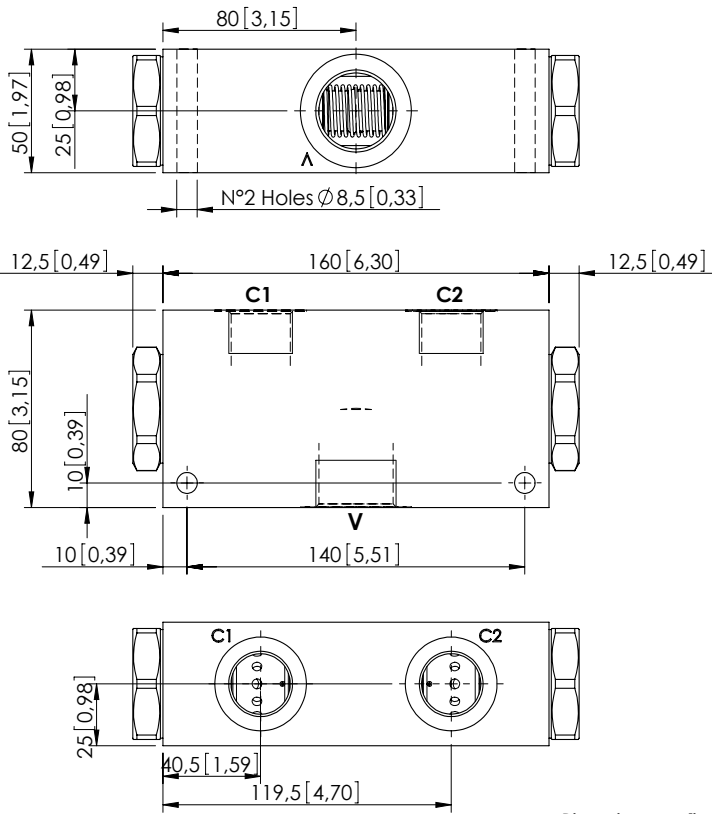

SPECIFICATIONS

Max. operating pressure:	210 bar (3000 psi)
Division or combination:	50 % - 50 %
Manifold:	Aluminium
Weight:	2,1 kg (4,63 lbs)
Contamination class to ISO 4406:	See technical spec.
MTTFa:	150 - 1200 years: See technical spec.

NOTES

Flow divider accuracy: $\pm 7/8\%$ between 40-100% of max. input flow.
 For other configurations/quick codes not available in this catalogue page please consult factory

CURVES

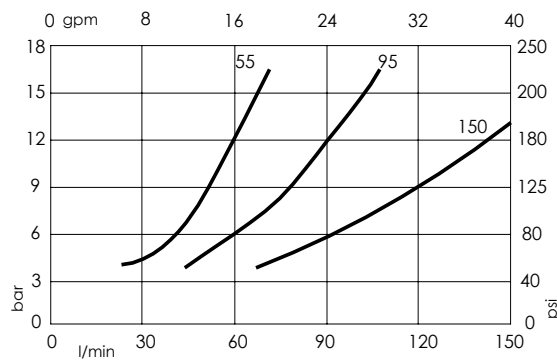

ORDERING CODES

Quick code	Description	Main ports size	Inlet range flow
MF000117	MFDT-150-BFLR-95-G10-N210	V: G 1"; C1,C2: G 3/4"	56 - 95 l/min (15-25 gpm)
MF000118	MFDT-150-BFLR-15-G10-N210	V: G 1"; C1,C2: G 3/4"	90 - 150 l/min (24-40 gpm)
MF000122	MFDT-150-BFLR-55-G34-N210	V: G 3/4"; C1,C2: G 1/2"	28 - 55 l/min (7.5-15 gpm)
MF000123	MFDT-150-BFLR-95-G34-N210	V: G 3/4"; C1,C2: G 1/2"	56 - 95 l/min (15-25 gpm)

FLOW DIVIDER AND COMBINER

KFDT-055-BFAR

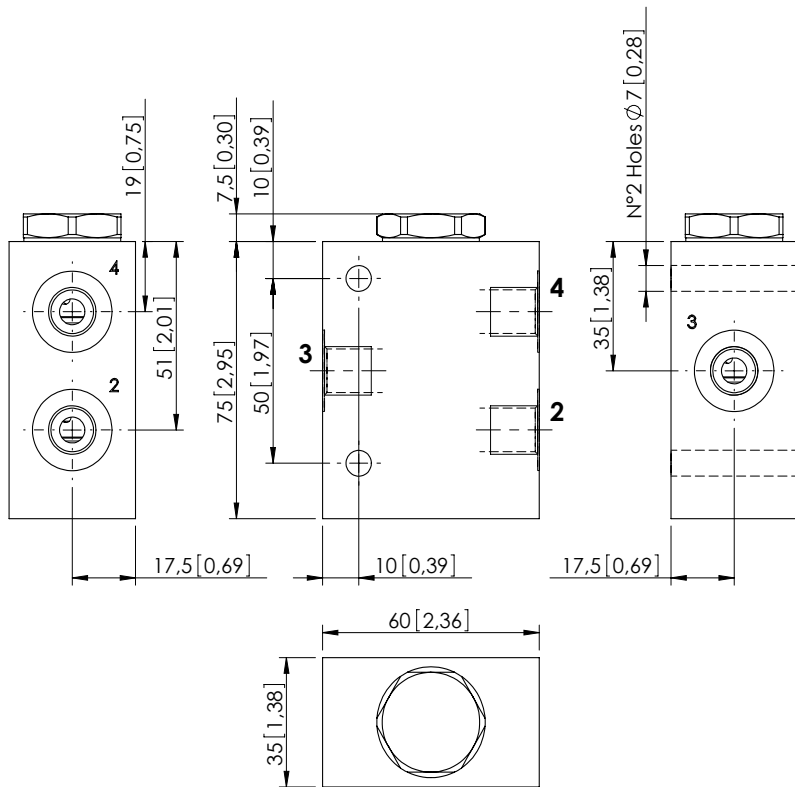

Dimensions: mm [inches]

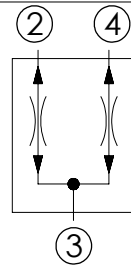

SPECIFICATIONS

Max. operating pressure:	210 bar (3000 psi)
Division or combination:	50 % - 50 %
Manifold:	Aluminium
Weight:	0,47 kg (1,01 lbs)
Cavity:	SAE-10-4N
Contamination class to ISO 4406:	See technical spec.
MTF _d :	150 - 1200 years: See technical spec.

NOTES

Flow divider accuracy: $\pm 7/8\%$ between 40-100% of max. input flow.
 For other configurations/quick codes not available in this catalogue page please consult factory

CURVES

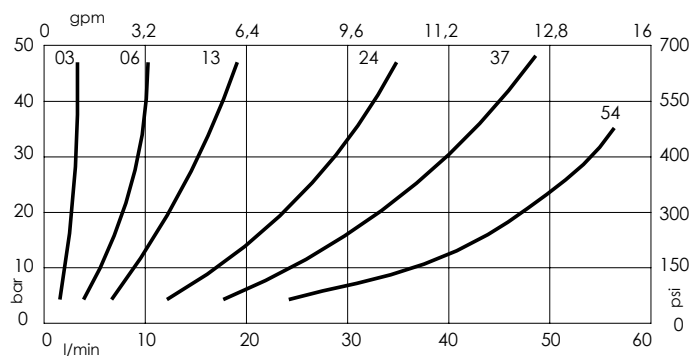

ORDERING CODES

Quick code	Description	Main ports size	Inlet range flow
KF000005	KFDT-055-BFAR-03-G14-N210-L	2,3,4 : G 1/4"	1,2-3 l/min (0,3-0,8 gpm)
KF000006	KFDT-055-BFAR-06-G14-N210-L	2,3,4 : G 1/4"	3-6 l/min (0,8-2 gpm)
KF000007	KFDT-055-BFAR-13-G14-N210-L	2,3,4 : G 1/4"	6-13 l/min (2-3,4 gpm)
KF000010	KFDT-055-BFAR-13-G38-N210-L	2,3,4 : G 3/8"	6-13 l/min (2-3,4 gpm)
KF000011	KFDT-055-BFAR-24-G38-N210-L	2,3,4 : G 3/8"	10-24 l/min (3-6 gpm)
KF000012	KFDT-055-BFAR-37-G38-N210-L	2,3,4 : G 3/8"	15-37 l/min (4-10 gpm)
KF000009	KFDT-055-BFAR-37-G12-N210-L	2,3,4 : G 1/2"	15-37 l/min (4-10 gpm)
KF000008	KFDT-055-BFAR-44-G12-N210-L	2,3,4 : G 1/2"	18-44 l/min (5-12 gpm)
KF000004	KFDT-055-BFAR-54-G12-N210-L	2,3,4 : G 1/2"	22-54 l/min (6-14 gpm)