

SOLENOID OPERATED CARTRIDGE

# CECS-050-FRPN

PROPORTIONAL VALVES  
FLOW REGULATOR  
3 WAYS COMBINATION

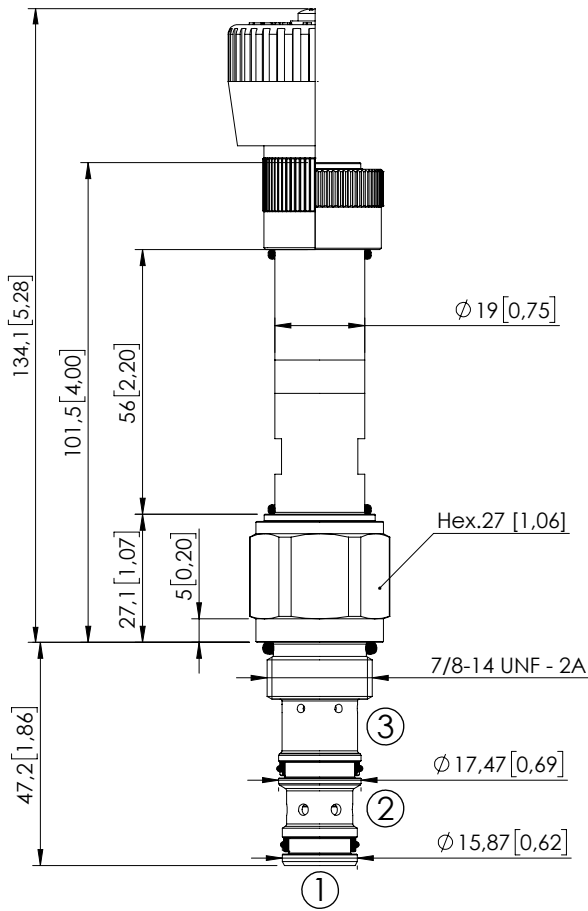

Dimensions: mm [inches]

3 way application

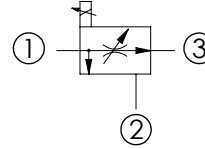

2 way application,  
port 2 not connected

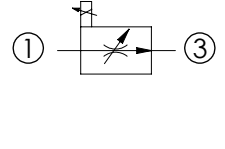

## SPECIFICATIONS

Max. operating pressure:	320 bar (4600 psi)
Max. flow (in inlet port ①):	50 l/min (13 gpm)
Max. flow ① to ③:	35 l/min REGULATED (9 gpm)
Cavity:	SAE-10-3N
Weight:	0,250 kg (0,55 lbs)
Type hydraulic fluid:	See Technical specif.
Hydraulic fluid temp. range:	-30/+100 °C (-22/+212 °F)
Contamination class to ISO 4406:	See technical spec.
Coil type:	M15 type
Voltage:	12- 24 V dc
Ambient temperature:	-20/+50 °C (-4/+122 °F)
Pressure differential (① to ③):	7-11 bar (101 - 159 psi)
Hysteresis (ramp up and down):	5 %
Max current (12 V dc):	1800 mA
Max current (24 V dc):	1200 mA
Coil resistance (12 V dc):	3.3-5.8 Ω
Coil resistance (24 V dc):	7.2-13 Ω
Surface protection proportional solenoid:	Coating DIN 50962 Fe8/ Zi-Ni with passivation
Installation torque:	55 - 62 Nm (41 - 46 ft-lb)
Seal kit:	RB100092
MTF <sub>a</sub> :	150 - 1200 years: See technical spec.

## NOTES

For other configurations/quick codes not available in this catalogue page please consult factory

## CURVES

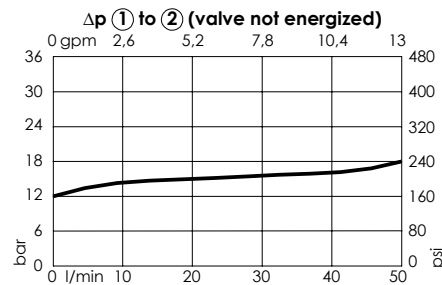
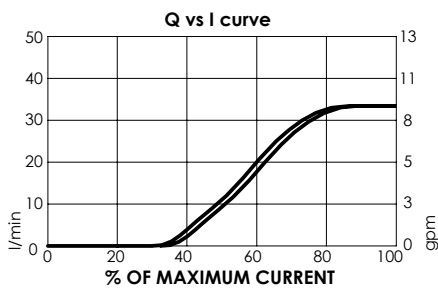

## ORDERING CODES

Quick code	Description	Regulated flow range	Adjustment type
CE001144	CECS-050-FRPN-35-S10-V320	0-35 l/min (0-9 gpm)	Standard
CE001882	CECS-050-FRPN-35-S10-V320	0-35 l/min (0-9 gpm)	Handknob